



**NLS-FR4060-30**

**NLS-FR4060-38**

**Desktop Barcode Scanner**

**User Guide**

## Disclaimer

© 2015-2016 Fujian Newland Auto-ID Tech. Co., Ltd. All rights reserved.

Please read through the manual carefully before using the product and operate it according to the manual. It is advised that you should keep this manual for future reference.

Do not disassemble the device or remove the seal label from the device, doing so will void the product warranty provided by Fujian Newland Auto-ID Tech. Co., Ltd.

All pictures in this manual are for reference only and actual product may differ. Regarding to the product modification and update, Fujian Newland Auto-ID Tech. Co., Ltd. reserves the right to make changes to any software or hardware to improve reliability, function, or design at any time without notice. The information contained herein is subject to change without prior notice.

The products depicted in this manual may include software copyrighted by Fujian Newland Auto-ID Tech. Co., Ltd or third party. The user, corporation or individual, shall not duplicate, in whole or in part, distribute, modify, decompile, disassemble, decode, reverse engineer, rent, transfer or sublicense such software without prior written consent from the copyright holders.

This manual is copyrighted. No part of this publication may be reproduced, distributed or used in any form without written permission from Newland.

Fujian Newland Auto-ID Tech. Co., Ltd. reserves the right to make final interpretation of the statement above.

Fujian Newland Auto-ID Tech. Co., Ltd.

3F, Building A, No.1, Rujiang West Rd., Mawei, Fuzhou, Fujian, China 350015

<http://www.nlscan.com>

## Revision History

| Version | Description  | Date              |
|---------|--|-------------------|
| V1.0.0  | Initial release.   | September 6, 2015 |
| V1.0.1  | <p>Updates:</p> <ol style="list-style-type: none"><li>1. Added the Inquire Product Information feature in Chapter 2.</li><li>2. Added the <b>Timeout between Decodes (Same Barcode)</b> feature for the Sense and Continuous modes in Chapter 4.</li><li>3. Added the <b>Polling Rate</b> feature and the Russian keyboard feature along with the programming procedure in Chapter 6.</li><li>4. Added the <b>Character Encoding</b> feature for PDF417, QR Code and Data Matrix in Chapter 8.</li></ol> <p><b>Note: You must have firmware version V1.00.016 or higher to use the new features above.</b></p> | June 2, 2016      |

# Table of Contents

|  |              |
|--|--------------|
| <b>Revision History .....</b>              | <b>- 3 -</b> |
| <b>Preface .....</b>                       | <b>1</b>     |
| Introduction .....                         | 1            |
| Chapter Description .....                  | 1            |
| Explanation of Icons .....                 | 2            |
| <b>Chapter 1 Getting Started .....</b>     | <b>3</b>     |
| Introduction .....                         | 3            |
| Features of the FR40 .....                 | 3            |
| Unpacking .....                            | 3            |
| FR40 Scanner .....                         | 4            |
| The Pinout of the Data Port (default)..... | 5            |
| Connecting the FR40 to a Host .....        | 5            |
| Using USB Cable .....                      | 6            |
| Using RS-232 Cable .....                   | 7            |
| Power On, Power Off, Reboot.....           | 8            |
| Maintenance.....                           | 8            |
| Dimensions (unit: mm) .....                | 9            |
| Left View .....                            | 9            |
| Front View.....                            | 9            |
| Right View.....                            | 10           |
| Scanning Instructions.....                 | 11           |
| <b>Chapter 2 System Settings .....</b>     | <b>12</b>    |
| Introduction .....                         | 12           |
| Barcode Programming .....                  | 12           |
| Command Programming.....                   | 12           |
| Programming Barcode/Command/Function ..... | 13           |
| Use of Programming Barcodes .....          | 13           |
| Beep.....                                  | 14           |
| Good Read Beep .....                       | 14           |
| Good Read Beep Type.....                   | 15           |
| Good Read Beep Volume .....                | 15           |

|   |           |
|---|-----------|
| Beep on Unknown Character .....             | 16        |
| Startup Beep .....                          | 16        |
| Beep Indications .....                      | 16        |
| Transmit NGR Message.....                   | 17        |
| Default Settings.....                       | 18        |
| Factory Defaults.....                       | 18        |
| Custom Defaults.....                        | 18        |
| Inquire Product Information.....            | 19        |
| <b>Chapter 3 Scanning Preferences .....</b> | <b>20</b> |
| <b>Chapter 4 Scan Mode.....</b>             | <b>21</b> |
| Sense Mode.....                             | 21        |
| Decode Session Timeout .....                | 21        |
| Timeout between Decodes (Same Barcode)..... | 22        |
| Batch Mode.....                             | 23        |
| Continuous Mode .....                       | 24        |
| Decode Session Timeout .....                | 24        |
| Timeout between Decodes.....                | 25        |
| Timeout between Decodes (Same Barcode)..... | 26        |
| <b>Chapter 5 RS-232 Interface.....</b>      | <b>27</b> |
| Introduction .....                          | 27        |
| RS-232 Parameters .....                     | 27        |
| Baud Rate .....                             | 28        |
| Parity Check.....                           | 29        |
| Data Bit .....                              | 30        |
| Data Bit & Parity Check.....                | 30        |
| Stop Bit.....                               | 31        |
| <b>Chapter 6 USB Interface .....</b>        | <b>32</b> |
| Introduction .....                          | 32        |
| USB HID-KBW .....                           | 32        |
| Polling Rate.....                           | 33        |
| USB Country Keyboard Types .....            | 34        |
| Beep on Unknown Character .....             | 37        |
| Inter-Keystroke Delay.....                  | 38        |
| Convert Case .....                          | 39        |

|                                     |           |
|-------------------------------------|-----------|
| Emulate ALT+Keypad.....             | 40        |
| Function Key Mapping .....          | 41        |
| Emulate Numeric Keypad .....        | 42        |
| Code Page .....                     | 42        |
| USB COM Port Emulation .....        | 43        |
| <b>Chapter 7 Symbologies.....</b>   | <b>44</b> |
| Introduction .....                  | 44        |
| Global Settings.....                | 44        |
| Disable All Symbologies.....        | 44        |
| Enable All Symbologies.....         | 44        |
| Enable 1D Symbologies.....          | 45        |
| Disable 1D Symbologies.....         | 45        |
| Enable 2D Symbologies.....          | 45        |
| Disable 2D Symbologies.....         | 45        |
| Video Reverse .....                 | 46        |
| 1D Symbologies.....                 | 47        |
| Code 128 .....                      | 47        |
| Restore Factory Defaults .....      | 47        |
| Enable/Disable Code 128 .....       | 47        |
| Set Length Range for Code 128 ..... | 48        |
| AIM-128 .....                       | 49        |
| Restore Factory Defaults .....      | 49        |
| Enable/Disable AIM-128 .....        | 49        |
| Set Length Range for AIM-128 .....  | 50        |
| GS1-128(UCC/EAN-128).....           | 51        |
| Restore Factory Defaults .....      | 51        |
| Enable/Disable UCC/EAN-128 .....    | 51        |
| EAN-8 .....                         | 52        |
| Restore Factory Defaults .....      | 52        |
| Enable/Disable EAN-8 .....          | 52        |
| Transmit Check Digit.....           | 52        |
| 2-Digit Add-On Code.....            | 53        |
| 5-Digit Add-On Code.....            | 54        |
| Add-On Code Required .....          | 55        |
| EAN-8 Extension.....                | 55        |

|   |    |
|---|----|
| EAN-13 .....                                  | 56 |
| Restore Factory Defaults .....                | 56 |
| Enable/Disable EAN-13 .....                   | 56 |
| Transmit Check Digit.....                     | 56 |
| 2-Digit Add-On Code.....                      | 57 |
| 5-Digit Add-On Code.....                      | 58 |
| UPC-E.....                                    | 59 |
| Restore Factory Defaults .....                | 59 |
| Enable/Disable UPC-E.....                     | 59 |
| Transmit Check Digit.....                     | 59 |
| 2-Digit Add-On Code.....                      | 60 |
| 5-Digit Add-On Code.....                      | 61 |
| Add-On Code Required .....                    | 62 |
| Transmit System Character "0" .....           | 62 |
| UPC-E Extension .....                         | 62 |
| UPC-A.....                                    | 63 |
| Restore Factory Defaults .....                | 63 |
| Enable/Disable UPC-A.....                     | 63 |
| Transmit Check Digit.....                     | 63 |
| 2-Digit Add-On Code.....                      | 64 |
| 5-Digit Add-On Code.....                      | 65 |
| Add-On Code Required .....                    | 66 |
| Transmit Preamble Character "0" .....         | 66 |
| Interleaved 2 of 5 .....                      | 67 |
| Restore Factory Defaults .....                | 67 |
| Enable/Disable Interleaved 2 of 5 .....       | 67 |
| Set Length Range for Interleaved 2 of 5 ..... | 68 |
| Check Digit Verification .....                | 69 |
| ITF-14 .....                                  | 70 |
| ITF-6 .....                                   | 71 |
| Matrix 2 of 5 .....                           | 72 |
| Restore Factory Defaults .....                | 72 |
| Enable/Disable Matrix 2 of 5.....             | 72 |
| Set Length Range for Matrix 2 of 5.....       | 73 |
| Check Digit Verification .....                | 74 |
| Code 39 .....                                 | 75 |

|  |    |
|--|----|
| Restore Factory Defaults .....             | 75 |
| Enable/Disable Code 39 .....               | 75 |
| Transmit Start/Stop Character .....        | 75 |
| Set Length Range for Code 39 .....         | 76 |
| Check Digit Verification .....             | 77 |
| Enable/Disable Code 39 Full ASCII .....    | 78 |
| Codabar .....                              | 79 |
| Restore Factory Defaults .....             | 79 |
| Enable/Disable Codabar .....               | 79 |
| Set Length Range for Codabar .....         | 80 |
| Check Digit Verification .....             | 81 |
| Start/Stop Character .....                 | 82 |
| Code 93 .....                              | 83 |
| Restore Factory Defaults .....             | 83 |
| Enable/Disable Code 93 .....               | 83 |
| Set Length Range for Code 93 .....         | 84 |
| Check Digit Verification .....             | 85 |
| GS1 Databar(RSS) .....                     | 86 |
| Restore Factory Defaults .....             | 86 |
| Enable/Disable GS1 Databar .....           | 86 |
| Transmit Application Identifier "01" ..... | 86 |
| Code 11 .....                              | 87 |
| Restore Factory Defaults .....             | 87 |
| Enable/Disable Code 11 .....               | 87 |
| Set Length Range for Code 11 .....         | 88 |
| Check Digit Verification .....             | 89 |
| ISSN .....                                 | 90 |
| Restore Factory Defaults .....             | 90 |
| Enable/Disable ISSN .....                  | 90 |
| Add-On Code .....                          | 91 |
| Add-On Code Required .....                 | 91 |
| ISBN .....                                 | 92 |
| Restore Factory Defaults .....             | 92 |
| Enable/Disable ISBN .....                  | 92 |
| Set ISBN Format .....                      | 92 |
| Industrial 25 .....                        | 93 |



|  |     |
|--|-----|
| Restore Factory Defaults .....           | 93  |
| Enable/Disable Industrial 25 .....       | 93  |
| Set Length Range for Industrial 25 ..... | 94  |
| Check Digit Verification .....           | 95  |
| Standard 25 (IATA 2 of 5) .....          | 96  |
| Restore Factory Defaults .....           | 96  |
| Enable/Disable Standard 25 .....         | 96  |
| Set Length Range for Standard 25.....    | 97  |
| Check Digit Verification .....           | 98  |
| Plessey .....                            | 99  |
| Restore Factory Defaults .....           | 99  |
| Enable/Disable Plessey .....             | 99  |
| Set Length Range for Plessey .....       | 100 |
| Check Digit Verification .....           | 101 |
| MSI-Plessey .....                        | 102 |
| Restore Factory Defaults .....           | 102 |
| Enable/Disable MSI-Plessey.....          | 102 |
| Set Length Range for MSI-Plessey.....    | 103 |
| Check Digit Verification .....           | 104 |
| 2D Symbolologies .....                   | 105 |
| PDF417.....                              | 105 |
| Restore Factory Defaults .....           | 105 |
| Enable/Disable PDF417.....               | 105 |
| Set Length Range for PDF417.....         | 106 |
| PDF417 Twin Code.....                    | 107 |
| Transmission Order of Twin Code.....     | 108 |
| Character Encoding .....                 | 108 |
| QR Code .....                            | 109 |
| Restore Factory Defaults .....           | 109 |
| Enable/Disable QR Code.....              | 109 |
| Set Length Range for QR Code.....        | 110 |
| QR Twin Code.....                        | 111 |
| Micro QR.....                            | 112 |
| Character Encoding .....                 | 112 |
| Data Matrix.....                         | 113 |
| Restore Factory Defaults .....           | 113 |

|  |            |
|--|------------|
| Enable/Disable Data Matrix .....                   | 113        |
| Set Length Range for Data Matrix.....              | 114        |
| Data Matrix Twin Code.....                         | 115        |
| Rectangular Barcode .....                          | 116        |
| Mirror Image .....                                 | 116        |
| Character Encoding .....                           | 116        |
| <b>Chapter 8 Prefix &amp; Suffix .....</b>         | <b>117</b> |
| Introduction .....                                 | 117        |
| Global Settings.....                               | 118        |
| Enable/Disable All Prefix/Suffix .....             | 118        |
| Prefix Sequences.....                              | 118        |
| Custom Prefix.....                                 | 119        |
| Enable/Disable Custom Prefix .....                 | 119        |
| Set Custom Prefix .....                            | 119        |
| AIM ID Prefix.....                                 | 120        |
| Code ID Prefix.....                                | 120        |
| Restore All Default Code IDs .....                 | 121        |
| Modify Code ID .....                               | 121        |
| Custom Suffix.....                                 | 125        |
| Enable/Disable Custom Suffix.....                  | 125        |
| Set Custom Suffix .....                            | 125        |
| Terminating Character Suffix .....                 | 126        |
| Enable/Disable Terminating Character Suffix.....   | 126        |
| Set Terminating Character Suffix.....              | 127        |
| <b>Appendix .....</b>                              | <b>128</b> |
| Appendix 1: Factory Defaults Table.....            | 128        |
| Appendix 2: AIM ID Table .....                     | 133        |
| Appendix 3: Code ID Table.....                     | 134        |
| Appendix 4: ASCII Table.....                       | 135        |
| Appendix 5: Digit Barcodes .....                   | 139        |
| Appendix 6: Save/Cancel Barcodes.....              | 141        |
| Appendix 7: ASCII Function Key Mapping Table ..... | 142        |
| Appendix 8: Code Pages List.....                   | 144        |

# Preface

## Introduction

This manual provides detailed instructions for setting up and using the NLS-FR4060-30/NLS-FR4060-38 desktop barcode scanner (hereinafter referred to as “**FR40 scanner**” or “**the scanner**”).

## Chapter Description

- ✧ *Chapter 1, Getting Started* : Gives a general description of FR40 scanner.
- ✧ *Chapter 2, System Settings* : Introduces configuration methods and describes how to configure general parameters of FR40 scanner.
- ✧ *Chapter 3, Scan Preferences* : Describes how to adjust the scanner to decode barcodes on different mediums.
- ✧ *Chapter 4, Scan Mode* : Describes how to configure scan mode.
- ✧ *Chapter 5, RS-232 Interface* : Describes how to configure RS-232 communication parameters.
- ✧ *Chapter 6, USB Interface* : Describes how to configure USB communication parameters.
- ✧ *Chapter 7, Symbologies* : Lists all supported symbologies and describes how to configure the relevant parameters..
- ✧ *Chapter 8, Prefix & Suffix* : Describes how to use prefix and suffix to customize scanned data.
- ✧ *Appendix* : Provides factory defaults table and a bunch of frequently used programming barcodes.

---

## Explanation of Icons



This icon indicates something relevant to this manual.



This icon indicates this information requires extra attention from the reader.



This icon indicates handy tips that can help you use or configure the scanner with ease.



This icon indicates practical examples that can help you to acquaint yourself with operations.

# Chapter 1 Getting Started

## Introduction

The FR40 scanner reads a 1D or 2D barcode by capturing its image. Adopting the advanced **UIMG** technology independently developed by Newland Auto-ID Tech, it provides users with Regular mode and Screen mode, tailored to different scanning needs.

An illustrated introduction to the FR40 scanner is included in this chapter. If you have an FR40 scanner at hand, make good use of it to develop a better understanding of this manual. This chapter is written for normal users, maintenance staff and software developers.

## Features of the FR40

- Comprehensive data capture: most 1D and 2D barcodes.
- Speedy and accurate decoding capability: integrates high-performance processor and barcode decoder board.
- Easy to configure and update.

## Unpacking

Open the package and take out FR40 scanner and its accessories. Check to make sure everything on the packing list is present and intact. If any contents are damaged or missing, please keep the original package and contact your dealer immediately for after-sales service.

---

## FR40 Scanner

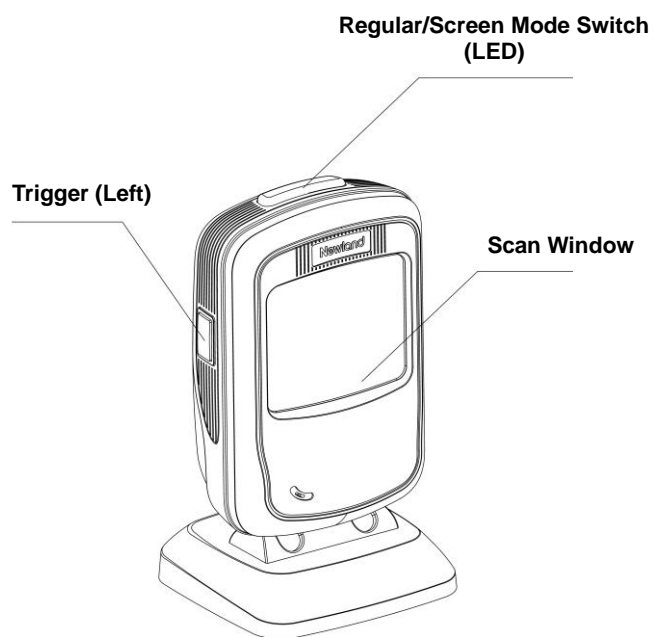

**Regular/Screen Mode Switch:**  
Press it to toggle between the Screen mode (red LED lights up) and Regular mode (green LED lights up).

**LED:**  
LED flashes once: Barcode is decoded.

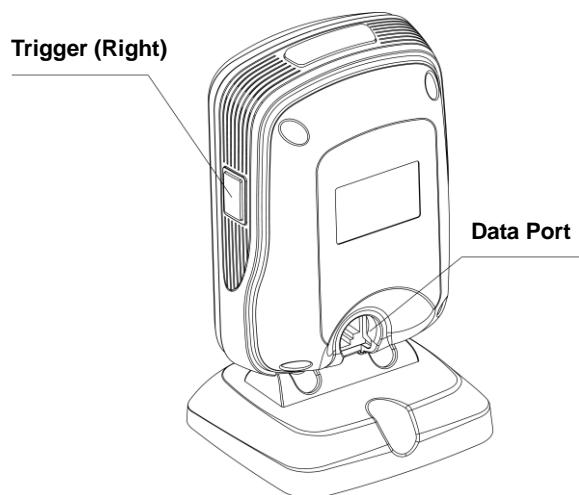

---

## The Pinout of the Data Port (default)

| PIN | Signal | Type | Function      |
|-----|--------|------|---------------|
| 1   | NC     | -    | No connection |
| 2   | NC     | -    | No connection |
| 3   | VCC    | P    | Power+ (+5V)  |
| 4   | TXD    | O    | RS-232 output |
| 5   | RXD    | I    | RS-232 input  |
| 6   | NC     | -    | No connection |
| 7   | NC     | -    | No connection |
| 8   | GND    | P    | Ground        |
| 9   | D-     | I/O  | USB signal    |
| 10  | D+     | I/O  |               |

## Connecting the FR40 to a Host

The FR40 scanner must be connected to a Host in actual application, such as PC, POS or any intelligent terminal with USB or RS-232 port, via a communication cable, either USB or RS-232 cable.

### USB

USB port on the Host

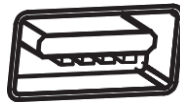

### RS-232

RS-232 port on the Host



---

## Using USB Cable

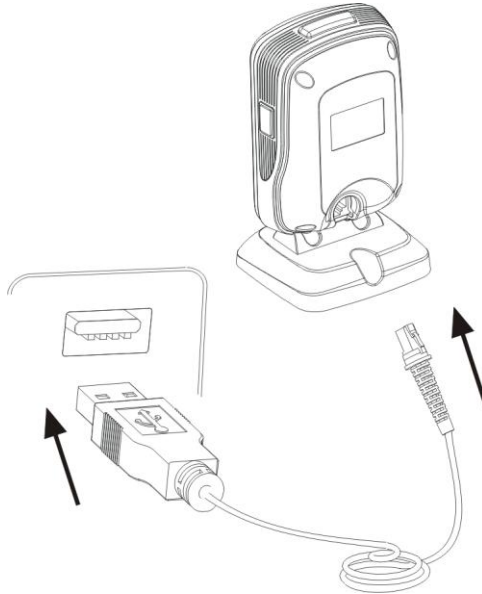

Connect the FR40 scanner to a Host through a USB cable with RJ45 and USB connectors:

1. Plug the RJ45 connector into the data port on the scanner.
2. Plug the USB connector into the USB port on the Host.



---

## Using RS-232 Cable

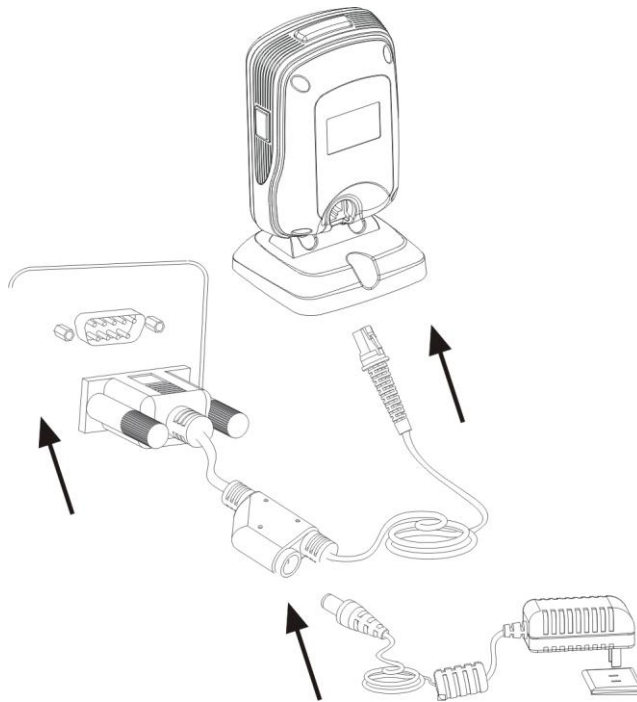

Connect the FR40 scanner to a Host through a RS-232 cable with RJ45, RS-232 and power connectors:

1. Plug the RJ45 connector into the data port on the scanner.
2. Plug the RS-232 connector into the RS-232 port on the Host.
3. Connect the supplied power adaptor to the power connector of the RS-232 cable.

---

## Power On, Power Off, Reboot

### Power on the scanner

Connect the FR40 scanner to a Host. Then the scanner will be turned on.

### Power off the scanner

Remove the communication cable from the FR40 scanner; or remove the USB cable from the Host; or disconnect the power adaptor from mains.

### Reboot the scanner

If the FR40 scanner stops responding to input or runs abnormally, turn off the scanner and then turn it back on.

## Maintenance

- ✧ The scan window should be kept clean.
- ✧ Do not scratch the scan window.
- ✧ Use soft brush to remove the stain from the scan window.
- ✧ Use the soft cloth to clean the window, such as eyeglass cleaning cloth.
- ✧ Do not spray any liquid on the scan window.
- ✧ Do not use any detergent to clean other parts of the device except for water.



The warranty **DOES NOT** cover damages caused by inappropriate care and maintenance.

---

**Dimensions (unit: mm)**

**Left View**

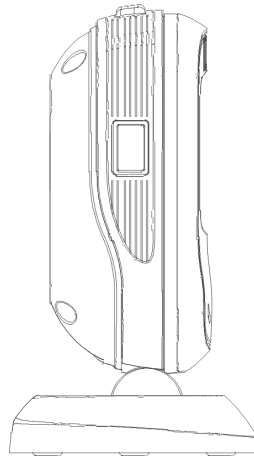

**Front View**

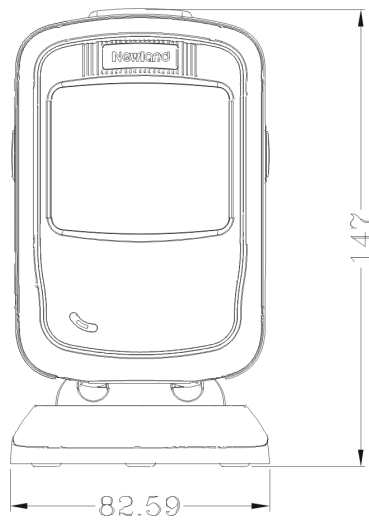

---

**Right View**

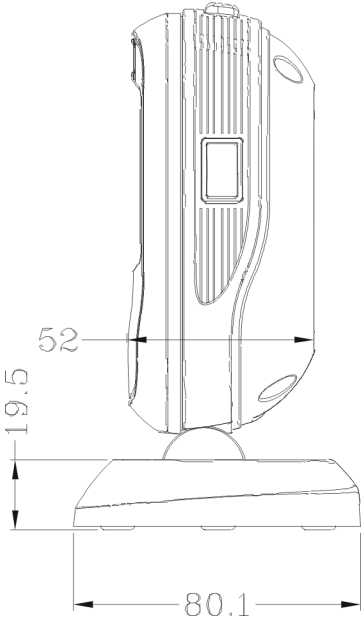

---

## Scanning Instructions

When the FR40 scanner is in the Sense scan mode, you can follow the steps below to scan a barcode:

1. Connect the scanner to a Host with the cable. Then the scanner will be powered on.
2. Present a barcode to the center of the scan window. Then the scanner will project a red beam and start to decode the barcode.
3. If the barcode is decoded successfully, the scanner will emit a good read beep and the decoded data will be sent to the Host.



0006010

**【Enter Setup】**

## Chapter 2 System Settings

### Introduction

There are two ways to configure the FR40 scanner: barcode programming and command programming.

#### Barcode Programming

The FR40 scanner can be configured through scanning a number of programming barcodes. In the following sections, we will explain the available options and features and provide the barcodes to program them.

This programming method is straightforward. However, it requires manually scanning barcodes. As a result, errors are likely to occur.

#### Command Programming

The FR40 scanner can also be configured by command strings sent from the Host. In the following sections, the commands will be provided along with programming barcodes.

Users can also develop an application to send those command strings to their scanners.



0006000

**\*\*【Exit Setup】**



0006010

**【Enter Setup】**

## Programming Barcode/Command/Function



The figure above is an example that shows you the programming barcode and command for the Exit Setup function:

1. The **Exit Setup** barcode
2. The **Exit Setup** command
3. The function/feature that can be enabled by using the programming barcode or command listed above.
4. \*\* indicates factory default settings.

## Use of Programming Barcodes

Scanning the **Enter Setup** barcode can enable the scanner to enter the setup mode. Then you can scan a number of programming barcodes to configure your scanner. To exit the setup mode, scan the **Exit Setup** barcode.

Some functions or options may involve parameter value settings that require scanning numeric barcodes. To find the numeric barcodes, see the “**Digit Barcodes**” section in **Appendix**.



0006000

**\*\* 【Exit Setup】**



0006010

**【Enter Setup】**



0006000

**\*\* 【Exit Setup】**



0006010

**【Enter Setup】**

---

Programming barcode data can be transmitted to the Host. Scan the appropriate barcode below to enable or disable the transmission of programming barcode data (programming commands) to the Host.



0002000

**\*\* 【Do Not Transmit Programming Barcode Data】**



0002010

**【Transmit Programming Barcode Data】**

## Beep

### Good Read Beep

Scanning the **Good Read Beep Off** barcode disables the scanner's ability to beep upon a successful decode of non-programming barcode; scanning the **Good Read Beep On** barcode can enable it.



0203010

**\*\* 【Good Read Beep On】**



0203000

**【Good Read Beep Off】**



0006000

**\*\* 【Exit Setup】**





0006010

**【Enter Setup】**

---

## Good Read Beep Type



0203020

**【Type 1】**



0203022

**\*\* 【Type 3】**



0203021

**【Type 2】**

## Good Read Beep Volume



0203030

**\*\* 【Loud】**



0203032

**【Low】**



0203031

**【Medium】**



0006000

**\*\* 【Exit Setup】**



0006010

**【Enter Setup】**

## Beep on Unknown Character

Due to the differences in keyboard layouts, some characters contained in barcode data may be unavailable on the selected keyboard. As a result, the scanner fails to transmit the unknown characters.

Scan the appropriate barcode below to enable or disable the emission of beep when an unknown character is detected.



1103030

**\*\* 【Do Not Beep on Unknown Character】**



1103031

**【Beep on Unknown Character】**

## Startup Beep



0204001

**\*\* 【Startup Beep On】**



0204000

**【Startup Beep Off】**

## Beep Indications

| Beep Sequence                      | Indication  |
|------------------------------------|---|
| 4 ascending beeps                  | The scanner is powered up (if the Startup Beep is on).  |
| 1 beep                             | A non-programming barcode was decoded (if the Good Read Beep is on).  |
| 2 beeps                            | A programming barcode was decoded.  |
| 3 short low beeps and 2 high beeps | The scanner failed to decode a programming barcode.   |
| 1 long low beep                    | The scanner detected an unknown character when using USB HID-KBW (if the Beep on Unknown Character is enabled). |



0006000

**\*\* 【Exit Setup】**



0006010

**【Enter Setup】**

---

## Transmit NGR Message

Scan the appropriate barcode below to select whether or not to transmit a user-defined NGR (Not Good Read) message when the scanner fails to decode a barcode.



0320010

**【Transmit NGR Message】**



0320000

**\*\* 【Do Not Transmit NGR Message】**

## Edit NGR Message

To edit an NGR message, scan the **Edit NGR Message** barcode and the numeric barcodes corresponding to the ASCII values (hex) of desired characters and then scan the **Save** barcode.

An NGR message can contain 0-7 characters (ASCII value of character: 0x00-0xFF).



0320020

**【Edit NGR Message】**

**E**  
*example*

### Example: Set the NGR message to “!ERR”

1. Check the hex values of “!ERR” in the ASCII Table. (“!ERR”: 21, 45, 52, 52)
2. Scan the **Enter Setup** barcode.
3. Scan the **Edit NGR Message** barcode.
4. Scan the numeric barcodes “2”, “1”, “4”, “5”, “5”, “2”, “5” and “2”.
5. Scan the **Save** barcode.
6. Scan the **Exit Setup** barcode.



0006000

**\*\* 【Exit Setup】**



0006010

**【Enter Setup】**

## Default Settings

### Factory Defaults

Scanning the following barcode can restore the scanner to the factory defaults.

You may need to reset all parameters to the factory defaults when:

- ✧ scanner is not properly configured so that it fails to decode barcodes.
- ✧ you forget previous configuration and want to avoid its impact.



0001000

**【Restore All Factory Defaults】**

### Custom Defaults

Custom defaults make it possible to save the frequently-used settings on the scanner.

Scanning the **Save as Custom Defaults** barcode can save the current settings as custom defaults. Once custom default settings are stored, they can be recovered at any time by scanning the **Restore All Custom Defaults** barcode.

Custom defaults are stored in the non-volatile memory and they won't be lost when power is removed.



0001150

**【Save as Custom Defaults】**



0001160

**【Restore All Custom Defaults】**



Restoring the scanner to the factory defaults will not remove the custom defaults from the scanner.



0006000

**\*\*【Exit Setup】**



0006010

**【Enter Setup】**

---

## Inquire Product Information

You can scan the barcode below to inquire the scanner information (such as firmware version, model number, serial number, manufacture date). The result will be sent to the Host.



9876537

**【Inquire Product Information】**



0006000

**\*\*【Exit Setup】**



0006010

**【Enter Setup】**

## Chapter 3 Scanning Preferences

The scanner can capture barcodes printed on paper labels or displayed on the screen of a mobile phone. Select a mode that fits your application..

- ◇ **Regular Mode:** Read barcodes printed on paper or objects.
- ◇ **Screen Mode:** Read barcodes off mobile phones or LCD displays.

### Switch between the Regular and Screen modes:

Method 1: Press the button at the top of the scanner.

Method 2: Scan the **Screen Mode** barcode to activate the Screen mode (indicated by red LED); scan the **Regular Mode** barcode to activate the Regular mode (indicated by green LED).



0313141

**\*\* 【Regular Mode】**



0313142

**【Screen Mode】**



0006000

**\*\* 【Exit Setup】**



0006010

**【Enter Setup】**

## Chapter 4 Scan Mode

### Sense Mode

If the Sense mode is enabled, presenting a barcode to the scanner activates a decode session. The session continues until the barcode decodes or the decode session timeout expires or the barcode is moved away from the scanner. Holding down the left or right trigger on the scanner can also activate a decode session. The presence of obstacle between the scanner and barcode can affect the trigger distance.



0302000

**\*\* 【Sense Mode】**

### Decode Session Timeout

This parameter sets the maximum time decode session continues during a scan attempt. If the timeout expires or the barcode decodes, the decode session stops. It is programmable in 1ms increments from 0ms to 3,600,000ms. The default setting is 3,000ms.



0313000

**【Decode Session Timeout】**

**E**  
*sample*

#### Example: Set the decode session timeout to 1500ms

1. Scan the **Enter Setup** barcode.
2. Scan the **Decode Session Timeout** barcode.
3. Scan the numeric barcodes "1", "5", "0" and "0".
4. Scan the **Save** barcode.
5. Scan the **Exit Setup** barcode.



0006000

**\*\* 【Exit Setup】**



0006010

**【Enter Setup】**

## Timeout between Decodes (Same Barcode)

Timeout between Decodes (Same Barcode) can avoid undesired rereading of same barcode in a given period of time.

To enable/disable the Timeout between Decodes (Same Barcode), scan the appropriate barcode below.

**Enable Timeout between Decodes:** Do not allow the scanner to re-read same barcode before the timeout between decodes (same barcode) expires.

**Disable Timeout between Decodes:** Allow the scanner to re-read same barcode.



0313020

\*\* **【Disable Timeout between Decodes】**



0313030

**【Enable Timeout between Decodes】**

The following parameter sets the timeout between decodes for same barcode. It is programmable in 1ms increments from 0ms to 65,535ms. The default setting is 1,500ms.



0313010

**【Timeout between Decodes (Same Barcode)】**

**E**  
*Example*

**Example: Set the timeout between decodes (same barcode) to 1000ms**

1. Scan the **Enter Setup** barcode.
2. Scan the **Decode Session Timeout** barcode.
3. Scan the numeric barcodes "1", "0", "0" and "0".
4. Scan the **Save** barcode.
5. Scan the **Exit Setup** barcode.



0006000

\*\* **【Exit Setup】**





0006010

**【Enter Setup】**

---

## Batch Mode

If the Batch Mode is enabled, presenting barcodes one after another to the scanner or holding down the left or right trigger activates a round of multiple decode sessions. This round of multiple scans continues until you release the trigger or stop presenting barcode to the scanner. Rereading a barcode in the same round is not allowed if it was decoded previously. After a round ends, you need to wait for 20ms or longer before you can start another round.



0302003

**【Batch Mode】**



0006000

**\*\* 【Exit Setup】**



0006010

**【Enter Setup】**

---

## Continuous Mode

If the Continuous mode is enabled, the scanner automatically activates one decode session after another.



0302020

**【Continuous Mode】**

## Decode Session Timeout

This parameter sets the maximum time decode session continues during a scan attempt. If the timeout expires or the barcode decodes, the decode session stops. It is programmable in 1ms increments from 0ms to 3,600,000ms. The default setting is 3,000ms.



0313040

**【Decode Session Timeout】**

**E**  
*example*

### Example: Set the decode session timeout to 1500ms

1. Scan the **Enter Setup** barcode.
2. Scan the **Decode Session Timeout** barcode.
3. Scan the numeric barcodes “1”, “5”, “0” and “0”.
4. Scan the **Save** barcode.
5. Scan the **Exit Setup** barcode.



0006000

**\*\*【Exit Setup】**



0006010

**【Enter Setup】**

---

## Timeout between Decodes

This parameter sets the timeout between decode sessions. When a decode session ends, next session will not happen until the timeout between decodes expires. It is programmable in 1ms increments from 0ms to 65,535ms. The default setting is 1,000ms.



0313040

**【Timeout between Decodes】**

**E**  
*sample*

### Example: Set the timeout between decodes to 500ms

1. Scan the **Enter Setup** barcode.
2. Scan the **Timeout between Decodes** barcode.
3. Scan the numeric barcodes "5", "0" and "0".
4. Scan the **Save** barcode.
5. Scan the **Exit Setup** barcode.



0006000

**\*\*【Exit Setup】**



0006010

**【Enter Setup】**

## Timeout between Decodes (Same Barcode)

Timeout between Decodes (Same Barcode) can avoid undesired rereading of same barcode in a given period of time.

To enable/disable the Timeout between Decodes (Same Barcode), scan the appropriate barcode below.

**Enable Timeout between Decodes:** Do not allow the scanner to re-read same barcode before the timeout between decodes (same barcode) expires.

**Disable Timeout between Decodes:** Allow the scanner to re-read same barcode.



0313020

**\*\* 【Disable Timeout between Decodes】**



0313030

**【Enable Timeout between Decodes】**

The following parameter sets the timeout between decodes for same barcode. It is programmable in 1ms increments from 0ms to 65,535ms. The default setting is 1,500ms.



0313010

**【Timeout between Decodes (Same Barcode)】**

**E**  
*sample*

**Example: Set the timeout between decodes (same barcode) to 1000ms**

1. Scan the **Enter Setup** barcode.
2. Scan the **Decode Session Timeout** barcode.
3. Scan the numeric barcodes "1", "0", "0" and "0".
4. Scan the **Save** barcode.
5. Scan the **Exit Setup** barcode.



0006000

**\*\* 【Exit Setup】**



0006010

**【Enter Setup】**

## Chapter 5 RS-232 Interface

### Introduction

When the scanner is connected to the RS-232 port of a Host, you need to scan the barcode below to enable RS-232 communication and set communication parameters (including baud rate, parity check, data bit and stop bit) to match the Host.



1100000

**【RS-232】**

### RS-232 Parameters

When the scanner is connected to the Host via serial port, it is necessary to maintain consistency in communication parameters configuration on both devices to ensure smooth communication between them. The default settings of the scanner are 9600bps, no parity check, 8 data bits and 1 stop bit.



0006000

**\*\* 【Exit Setup】**



0006010

**【Enter Setup】**

---

## Baud Rate

Baud rate is the number of bits of data transmitted per second. Set the baud rate to match the Host requirements.



0100030

**\*\*【9600】**



0100050

**【19200】**



0100000

**【1200】**



0100060

**【38400】**



0100010

**【2400】**



0100070

**【57600】**



0100020

**【4800】**



0100080

**【115200】**



0100040

**【14400】**



0006000

**\*\*【Exit Setup】**



0006010

**【Enter Setup】**

---

## Parity Check

Set the parity type to match the Host requirements.

- ◇ **Odd Parity:** If the data contains an odd number of 1 bits, the parity bit value is set to 0.
- ◇ **Even Parity:** If the data contains an even number of 1 bits, the parity bit value is set to 0.
- ◇ **None:** Select this option when no parity bit is required.



0101000

**\*\* 【None】**



0101020

**【Odd Parity】**



0101010

**【Even Parity】**



0006000

**\*\* 【Exit Setup】**



0006010

**【Enter Setup】**

---

## Data Bit

Set the number of data bits to match the Host requirements.



0103030

**\*\* 【8 Data Bits】**



0103020

**【7 Data Bits】**

## Data Bit & Parity Check



0105010

**【7 Data Bits/Even Parity】**



0105020

**【7 Data Bits/Odd Parity】**



0105030

**\*\* 【8 Data Bits/ No Parity】**



0105040

**【8 Data Bits/Even Parity】**



0105050

**【8 Data Bits/Odd Parity】**



0006000

**\*\* 【Exit Setup】**





0006010

**【Enter Setup】**

---

## Stop Bit

The stop bit(s) at the end of each transmitted character marks the end of transmission of one character and prepares the receiving device for the next character in the serial data stream. Set the number of stop bits to match the Host requirements.



0102000

**\*\* 【1 Stop Bit】**



0102010

**【2 Stop Bits】**



0006000

**\*\* 【Exit Setup】**



0006010

**【Enter Setup】**

## Chapter 6 USB Interface

### Introduction

There are two options for USB connection.

- ◇ USB HID-KBW: The scanner's transmission is simulated as USB keyboard input with no need for command configuration or a driver. The barcode data could be entered by the virtual keyboard directly and it is also convenient for the Host to receive data.
- ◇ USB COM Port Emulation: The USB port on the Host is emulated as a RS-232 port with the same data transmission and configuration as a real RS-232 port. This mode is based on USB DataPipe protocol and thus requires a driver.

### USB HID-KBW

When the scanner is connected to the USB port on a Host, you can enable the USB HID-KBW feature by scanning the barcode below. The scanner's transmission will be simulated as USB keyboard input. The Host receives keystrokes on the virtual keyboard. It works on a Plug and Play basis and no driver is required.



1100020

**\*\* 【USB HID-KBW】**



If the Host allows keyboard input, then no extra software is needed for HID-KBW input.



0006000

**\*\* 【Exit Setup】**



0006010

**【Enter Setup】**

---

## Polling Rate

This parameter specifies the polling rate for a USB keyboard. If the Host drops characters, change the polling rate to a bigger value.



1103170

**\*\* 【1ms】**



1103171

**【2ms】**



1103172

**【3ms】**



1103173

**【4ms】**



1103174

**【5ms】**



1103175

**【6ms】**



1103176

**【7ms】**



1103177

**【8ms】**



1103178

**【9ms】**



1103179

**【10ms】**



0006000

**\*\* 【Exit Setup】**

---



0006010

**【Enter Setup】**

---

## USB Country Keyboard Types

Keyboard layouts may vary from country to country. The default setting is US keyboard type.



1103001

**\*\* 【U.S.】**



1103002

**【Japan】**



1103003

**【Denmark】**



1103004

**【Finland】**



1103005

**【France】**



1103006

**【Turkey\_F】**



1103007

**【Italy】**



1103008

**【Norway】**



0006000

**\*\* 【Exit Setup】**



0006010

**【Enter Setup】**

---



1103222

**【Spain】**



1103226

**【Turkey\_Q】**



1103227

**【UK】**



1103209

**【Austria, Germany】**



1103202

**【Belgium】**



1103220

**【Russia】**



1103223

**【Sweden】**

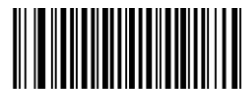

1103218

**【Portugal】**



0006000

**\*\* 【Exit Setup】**



0006010

**【Enter Setup】**

---

## **E** *example*

**Set the scanner to get proper output for Russian encoded with Windows 1251 (PDF417/QR Code/Data Matrix)**

1. Scan the **Enter Setup** barcode.
2. Scan the **Set the Code Page** barcode from the “**Code Page**” section in Chapter 6.
3. Scan the numeric barcode “1” from Appendix 5.
4. Scan the **Save** barcode from Appendix 6.
5. Scan the appropriate **Default Character Encoding** barcode according to the symbology your application needs from the “**Character Encoding**” section in Chapter 7.
6. Scan the **Russia** barcode from the “**USB Country Keyboard Types**” section in Chapter 6.
7. Scan the **Mode 3** barcode from the “**Emulate ALT+Keypad**” section in Chapter 6.
8. Scan the **Exit Setup** barcode.

## **E** *example*

**Set the scanner to get proper output for Russian encoded with UTF-8 (PDF417/QR Code/Data Matrix)**

1. Scan the **Enter Setup** barcode.
2. Scan the **Set the Code Page** barcode from the “**Code Page**” section in Chapter 6.
3. Scan the numeric barcode “1” from Appendix 5.
4. Scan the **Save** barcode from Appendix 6.
5. Scan the appropriate **UTF-8** barcode according to the symbology your application needs from the “**Character Encoding**” section in Chapter 7.
6. Scan the **Russia** barcode from the “**USB Country Keyboard Types**” section in Chapter 6.
7. Scan the **Mode 3** barcode from the “**Emulate ALT+Keypad**” section in Chapter 6.
8. Scan the **Exit Setup** barcode.



0006000

**\*\* 【Exit Setup】**



0006010

**【Enter Setup】**

---

## Beep on Unknown Character

Due to the differences in keyboard layouts, some characters contained in barcode data may be unavailable on the selected keyboard. As a result, the scanner fails to transmit the unknown characters.

Scan the appropriate barcode below to enable or disable the emission of beep when an unknown character is detected.



1103030

**\*\* 【Do Not Beep on Unknown Character】**



1103031

**【Beep on Unknown Character】**

**E**  
*example*

Supposing French keyboard is selected and barcode data "ADF" is being dealt with, the keyboard will fail to locate the "Ð" (0xD0) character and the scanner will ignore the character and continue to process the next one.

**Do Not Beep on Unknown Character:** The scanner does not beep and the Host receives "AF".

**Beep on Unknown Character:** The scanner beeps and the Host still receives "AF".



0006000

**\*\* 【Exit Setup】**



0006010

**【Enter Setup】**

---

## Inter-Keystroke Delay

This parameter specifies the delay between emulated keystrokes. It is programmable in 5ms increments from 0ms to 75ms. Single-digit values must have a leading zero. The default setting is 10ms.



1103050

**\*\* 【No Delay】**



1103052

**【Long Delay (40ms)】**



1103051

**【Short Delay (20ms)】**



1103053

**【Custom Delay】**

**E**  
*xample*

**Set the inter-keystroke delay to 5ms**

1. Scan the **Enter Setup** barcode.
2. Scan the **Custom Delay** barcode.
3. Scan the numeric barcodes "0" and "5".
4. Scan the **Exit Setup** barcode.



0006000

**\*\* 【Exit Setup】**





0006010

**【Enter Setup】**

---

## Convert Case

Scan the appropriate barcode below to convert all bar code data to your desired case.



1103040

**\*\* 【No Case Conversion】**



1103043

**【Invert Upper and Lower Case Characters】**



1103041

**【Convert All to Upper Case】**



1103042

**【Convert All to Lower Case】**

**E**  
*xample*

When the **Invert Upper and Lower Case Characters** feature is enabled, barcode data “AbC” is transmitted as “aBc”.



0006000

**\*\* 【Exit Setup】**



0006010

【Enter Setup】

## Emulate ALT+Keypad

This feature allows any ASCII character (0x00 - 0xFF) to be sent over the numeric keypad no matter which keyboard type is selected. Since sending a character involves multiple keystroke emulations, this method appears less efficient.

The following options are available:

- **Disable:** No ASCII character is sent in the ALT+Keypad way.
- **Mode 1:** ASCII characters not supported by the selected keyboard type but falling into 0x20~0xFF are sent in the ALT+Keypad way.
- **Mode 2:** ASCII characters falling into 0x20~0xFF are sent in the ALT+Keypad way.
- **Mode 3:** All ASCII characters (0x00~0xFF) are sent in the ALT+Keypad way.

**Note:** In the event of a conflict between **Function Key Mapping** and **Mode 3, Function Key Mapping** shall govern.



1103060

\*\* 【Disable】



1103061

【Mode 1】



1103062

【Mode 2】



1103063

【Mode 3】

**E**  
*sample*

Supposing US keyboard is selected, barcode data "ADF" (65/208/70) is sent as below:

(1) **Mode 1** is enabled:

"A" -- Keystroke "A"

"D" -- "ALT Make" + "208" + "ALT Break"

"F" -- Keystroke "F"

(2) **Mode 3** is enabled:

"A" -- "ALT Make" + "065" + "ALT Break"

"D" -- "ALT Make" + "208" + "ALT Break"

"F" -- "ALT Make" + "070" + "ALT Break"



0006000

\*\* 【Exit Setup】



0006010

**【Enter Setup】**

## Function Key Mapping

When Function Key Mapping is enabled, function characters (0x00 - 0x1F) are sent as ASCII sequences over the keypad. For more information, see **Appendix 7: ASCII Function Key Mapping Table**.



1103140

**【Enable Function Key Mapping】**



1103130

**\*\*【Disable Function Key Mapping】**

**E**  
*sample*

Barcode data 0x16

|  |                              |        |
|--|------------------------------|--------|
| <br>T | Enable Function Key Mapping  | Ctrl+V |
|  | Disable Function Key Mapping | F1     |



0006000

**\*\*【Exit Setup】**



0006010

**【Enter Setup】**

## Emulate Numeric Keypad

When this feature is disabled, sending barcode data is emulated as keystroke(s) on main keyboard.

To enable this feature, scan the **Emulate Numeric Keypad** barcode. Sending a number (0-9) is emulated as keystroke(s) on numeric keypad, whereas sending other characters like “+”, “\_”, “\*”, “/” and “.” is still emulated as keystrokes on main keyboard.



1103110

**\*\* 【Do Not Emulate Numeric Keypad】**



1103120

**【Emulate Numeric Keypad】**

## Code Page

In order to support more international characters, the **Code Page** programming feature is provided. This feature is only effective when ASCII characters are sent in the ALT+Keypad way. Programming a code page requires scanning numeric barcode (For more information, see **Appendix 8: Code Pages List**). The default code page is Windows 1252 (Latin I).



1103180

**【Set the Code Page】**

**E**  
*Example*

**Example: Set the code page to Windows 1252 (Latin I)**

1. Scan the **Enter Setup** barcode.
2. Scan the **Set the Code Page** barcode.
3. Scan the numeric barcode “0”.
4. Scan the **Save** barcode.
5. Scan the **Exit Setup** barcode.



0006000

**\*\* 【Exit Setup】**



0006010

**【Enter Setup】**

---

## USB COM Port Emulation

If your scanner is connected to the USB port on a Host, the USB COM Port Emulation feature allows the Host to receive data in the way as a serial port does. However, you need to set communication parameters on the scanner to match the Host requirements. A driver is required for this feature.



1100060

**【USB COM Port Emulation】**



0006000

**\*\* 【Exit Setup】**



0006010

**【Enter Setup】**

## Chapter 7 Symbologies

### Introduction

Every symbology (barcode type) has its own unique attributes. This chapter provides programming barcodes for configuring the scanner so that it can identify various barcode symbologies. The more symbologies you enable, the more slowly your scanner decodes. It is recommended to disable those that are rarely used to improve the performance of the scanner.

### Global Settings

#### Disable All Symbologies

If the **Disable All Symbologies** feature is enabled, the scanner can only identify the programming barcodes.



0001010

**【Disable All Symbologies】**

#### Enable All Symbologies

If the **Enable All Symbologies** feature is enabled, the scanner will be able to read all supported barcode symbologies as well as the programming barcodes.



0001020

**【Enable All Symbologies】**



0006000

**\*\*【Exit Setup】**



0006010

**【Enter Setup】**

---

### Enable 1D Symbologies



0001040

**【Enable 1D Symbologies】**

### Disable 1D Symbologies



0001030

**【Disable 1D Symbologies】**

### Enable 2D Symbologies



0001060

**【Enable 2D Symbologies】**

### Disable 2D Symbologies



0001050

**【Disable 2D Symbologies】**



0006000

**\*\* 【Exit Setup】**



**【Enter Setup】**

---

## Video Reverse

Regular barcode: Dark image on a bright background.

Inverse barcode: Bright image on a dark background.

The examples of regular barcode and inverse barcode are shown below.

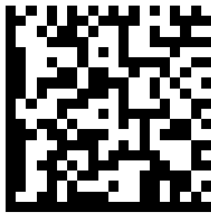

**Regular Barcode**

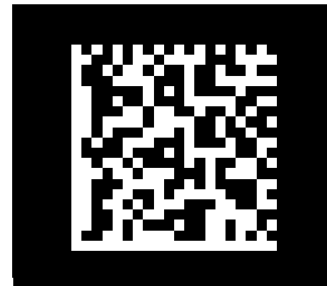

**Inverse Barcode**

Video Reverse is used to allow the scanner to read barcodes that are inverted.

**Video Reverse ON:** Read both regular barcodes and inverse barcodes.

**Video Reverse OFF** (default): Read regular barcodes only.

The scanner shows a slight decrease in scanning speed when Video Reverse is ON.



**【Video Reverse ON】**



**\*\* 【Video Reverse OFF】**



**\*\* 【Exit Setup】**





0006010

**【Enter Setup】**

---

## 1D Symbologies

### Code 128

#### Restore Factory Defaults



0400000

**\*\* 【Restore the Factory Defaults of Code 128】**

#### Enable/Disable Code 128



0400010

**【Disable Code 128】**



0400020

**\*\* 【Enable Code 128】**



If the scanner fails to identify Code 128 barcodes, you may first try this solution by scanning the **Enter Setup** barcode and then **Enable Code 128** barcode.



0006000

**\*\* 【Exit Setup】**



0006010

**【Enter Setup】**

### Set Length Range for Code 128

The scanner can be configured to only decode Code 128 barcodes with lengths that fall between (inclusive) the minimum and maximum lengths. To accomplish it, you need to set the minimum and maximum lengths.



0400030

**【Set the Minimum Length (Default: 1)】**



0400040

**【Set the Maximum Length (Default: 127)】**



If minimum length is set to be greater than maximum length, the scanner only decodes Code 128 barcodes with either the minimum or maximum length. If minimum length is same as maximum length, only Code 128 barcodes with that length are to be decoded.

**E**  
*xample*

**Set the scanner to decode Code 128 barcodes containing between 8 and 12 characters:**

1. Scan the **Enter Setup** barcode.
2. Scan the **Set the Minimum Length** barcode.
3. Scan the numeric barcode "8".
4. Scan the **Save** barcode.
5. Scan the **Set the Maximum Length** barcode.
6. Scan the numeric barcode "1".
7. Scan the numeric barcode "2".
8. Scan the **Save** barcode.
9. Scan the **Exit Setup** barcode.



0006000

**\*\*【Exit Setup】**



0006010

**【Enter Setup】**

---

## AIM-128

### Restore Factory Defaults



0423000

**【Restore the Factory Defaults of AIM-128】**

### Enable/Disable AIM-128



0423020

**\*\* 【Enable AIM-128】**



0423010

**【Disable AIM-128】**



If the scanner fails to identify AIM-128 barcodes, you may first try this solution by scanning the **Enter Setup** barcode and then **Enable AIM-128** barcode.



0006000

**\*\* 【Exit Setup】**



0006010

**【Enter Setup】**

### Set Length Range for AIM-128

The scanner can be configured to only decode AIM-128 barcodes with lengths that fall between (inclusive) the minimum and maximum lengths. To accomplish it, you need to set the minimum and maximum lengths.



0423030

**【Set the Minimum Length (Default: 1)】**



0423040

**【Set the Maximum Length (Default: 127)】**



If minimum length is set to be greater than maximum length, the scanner only decodes AIM-128 barcodes with either the minimum or maximum length. If minimum length is same as maximum length, only Code 128 barcodes with that length are to be decoded.



**Set the scanner to decode AIM-128 barcodes containing between 8 and 12 characters:**

1. Scan the **Enter Setup** barcode.
2. Scan the **Set the Minimum Length** barcode.
3. Scan the numeric barcode "8".
4. Scan the **Save** barcode.
5. Scan the **Set the Maximum Length** barcode.
6. Scan the numeric barcode "1".
7. Scan the numeric barcode "2".
8. Scan the **Save** barcode.
9. Scan the **Exit Setup** barcode.



0006000

**\*\*【Exit Setup】**



0006010

**【Enter Setup】**

---

## GS1-128(UCC/EAN-128)

### Restore Factory Defaults



0412000

**\*\* 【Restore the Factory Defaults of UCC/EAN-128】**

### Enable/Disable UCC/EAN-128



0412020

**\*\* 【Enable UCC/EAN-128】**



0412010

**【Disable UCC/EAN-128】**



If the scanner fails to identify UCC/EAN-128 barcodes, you may first try this solution by scanning the **Enter Setup** barcode and then **Enable UCC/EAN-128** barcode.



0006000

**\*\* 【Exit Setup】**



0006010

**【Enter Setup】**

---

## EAN-8

### Restore Factory Defaults



0401000

**\*\* 【Restore the Factory Defaults of EAN-8】**

### Enable/Disable EAN-8



0401020

**\*\* 【Enable EAN-8】**



0401010

**【Disable EAN-8】**

### Transmit Check Digit

EAN-8 is 8 digits in length with the last one as its check digit used to verify the integrity of the data.



0401040

**\*\* 【Transmit EAN-8 Check Digit】**



0401030

**【Do Not Transmit EAN-8 Check Digit】**

---



0006000

**\*\* 【Exit Setup】**



0006010

**【Enter Setup】**

## 2-Digit Add-On Code

An EAN-8 barcode can be augmented with a two-digit add-on code to form a new one. In the example below, the part surrounded by blue dotted line is an EAN-8 barcode while the part circled by red dotted line is a two-digit add-on code.



0401050

**\*\* 【Disable 2-Digit Add-On Code】**



0401060

**【Enable 2-Digit Add-On Code】**



**Disable 2-Digit Add-On Code:** The scanner decodes EAN-8 and ignores the add-on code when presented with an EAN-8 plus 2-digit add-on barcode. It can also decode EAN-8 barcodes without 2-digit add-on codes.

**Enable 2-Digit Add-On Code:** The scanner decodes a mix of EAN-8 barcodes with and without 2-digit add-on codes.



0006000

**\*\* 【Exit Setup】**



**【Enter Setup】**

### 5-Digit Add-On Code

An EAN-8 barcode can be augmented with a five-digit add-on code to form a new one. In the example below, the part surrounded by blue dotted line is an EAN-8 barcode while the part circled by red dotted line is a five-digit add-on code.



**\*\* 【Disable 5-Digit Add-On Code】**



**【Enable 5-Digit Add-On Code】**



**Disable 5-Digit Add-On Code:** The scanner decodes EAN-8 and ignores the add-on code when presented with an EAN-8 plus 5-digit add-on barcode. It can also decode EAN-8 barcodes without 5-digit add-on codes.

**Enable 5-Digit Add-On Code:** The scanner decodes a mix of EAN-8 barcodes with and without 5-digit add-on codes.



**\*\* 【Exit Setup】**





0006010

**【Enter Setup】**

---

### Add-On Code Required



0401110

**【EAN-8 Add-On Code Required】**



0401120

**\*\* 【EAN-8 Add-On Code Not Required】**

### EAN-8 Extension

- ◇ **Disable EAN-8 Zero Extend:** Transmit EAN-8 barcodes as is.
- ◇ **Enable EAN-8 Zero Extend:** Add five leading zeros to decoded EAN-8 barcodes to extend to 13 digits.



0401090

**\*\* 【Disable EAN-8 Zero Extend】**



0401100

**【Enable EAN-8 Zero Extend】**



0006000

**\*\* 【Exit Setup】**



0006010

**【Enter Setup】**

---

## EAN-13

### Restore Factory Defaults



0402000

**\*\* 【Restore the Factory Defaults of EAN-13】**

### Enable/Disable EAN-13



0402020

**\*\* 【Enable EAN-13】**



0402010

**【Disable EAN-13】**

### Transmit Check Digit



0402040

**\*\* 【Transmit EAN-13 Check Digit】**



0402030

**【Do Not Transmit EAN-13 Check Digit】**



0006000

**\*\* 【Exit Setup】**



0006010

**【Enter Setup】**

## 2-Digit Add-On Code

An EAN-13 barcode can be augmented with a two-digit add-on code to form a new one. In the example below, the part surrounded by blue dotted line is an EAN-13 barcode while the part circled by red dotted line is a two-digit add-on code.



0402050

**\*\* 【Disable 2-Digit Add-On Code】**



0402060

**【Enable 2-Digit Add-On Code】**



**Disable 2-Digit Add-On Code:** The scanner decodes EAN-13 and ignores the add-on code when presented with an EAN-13 plus 2-digit add-on barcode. It can also decode EAN-13 barcodes without 2-digit add-on codes.

**Enable 2-Digit Add-On Code:** The scanner decodes a mix of EAN-13 barcodes with and without 2-digit add-on codes.



0006000

**\*\* 【Exit Setup】**



**【Enter Setup】**

### 5-Digit Add-On Code

An EAN-13 barcode can be augmented with a five-digit add-on code to form a new one. In the example below, the part surrounded by blue dotted line is an EAN-13 barcode while the part circled by red dotted line is a five-digit add-on code.



**\*\* 【Disable 5-Digit Add-On Code】**



**【Enable 5-Digit Add-On Code】**



**Disable 5-Digit Add-On Code:** The scanner decodes EAN-13 and ignores the add-on code when presented with an EAN-13 plus 5-digit add-on barcode. It can also decode EAN-13 barcodes without 5-digit add-on codes.

**Enable 5-Digit Add-On Code:** The scanner decodes a mix of EAN-13 barcodes with and without 5-digit add-on codes.



**\*\* 【Exit Setup】**



0006010

**【Enter Setup】**

## UPC-E

### Restore Factory Defaults



0403000

**\*\* 【Restore the Factory Defaults of UPC-E】**

### Enable/Disable UPC-E



0403020

**\*\* 【Enable UPC-E】**



0403010

**【Disable UPC-E】**



If the scanner fails to identify UPC-E barcodes, you may first try this solution by scanning the **Enter Setup** barcode and then **Enable UPC-E** barcode.

### Transmit Check Digit

UPC-E is 8 digits in length with the last one as its check digit used to verify the integrity of the data.



0403040

**\*\* 【Transmit UPC-E Check Digit】**



0403030

**【Do Not Transmit UPC-E Check Digit】**



0006000

**\*\* 【Exit Setup】**



0006010

**【Enter Setup】**

## 2-Digit Add-On Code

A UPC-E barcode can be augmented with a two-digit add-on code to form a new one. In the example below, the part surrounded by blue dotted line is a UPC-E barcode while the part circled by red dotted line is a two-digit add-on code.



0403050

**\*\* 【Disable 2-Digit Add-On Code】**



0403060

**【Enable 2-Digit Add-On Code】**



**Disable 2-Digit Add-On Code:** The scanner decodes UPC-E and ignores the add-on code when presented with a UPC-E plus 2-digit add-on barcode. It can also decode UPC-E barcodes without 2-digit add-on codes.

**Enable 2-Digit Add-On Code:** The scanner decodes a mix of UPC-E barcodes with and without 2-digit add-on codes.



0006000

**\*\* 【Exit Setup】**



0006010

**【Enter Setup】**

## 5-Digit Add-On Code

A UPC-E barcode can be augmented with a five-digit add-on code to form a new one. In the example below, the part surrounded by blue dotted line is a UPC-E barcode while the part circled by red dotted line is a five-digit add-on code.



0403070

**\*\* 【Disable 5-Digit Add-On Code】**



0403080

**【Enable 5-Digit Add-On Cod】**



**Disable 5-Digit Add-On Code:** The scanner decodes UPC-E and ignores the add-on code when presented with a UPC-E plus 5-digit add-on barcode. It can also decode UPC-E barcodes without 5-digit add-on codes.

**Enable 5-Digit Add-On Code:** The scanner decodes a mix of UPC-E barcodes with and without 5-digit add-on codes.



0006000

**\*\* 【Exit Setup】**



0006010

**【Enter Setup】**

### Add-On Code Required



0403130

**【UPC-E Add-On Code Required】**



0403140

**\*\* 【UPC-E Add-On Code Not Required】**

### Transmit System Character “0”

The first character of UPC-E barcode is the system character “0”.



0403090

**\*\* 【Do Not Transmit System Character “0”】**



0403100

**【Transmit System Character “0”】**

### UPC-E Extension

- ◇ **Disable UPC-E Extend:** Transmit UPC-E barcodes as is.
- ◇ **Enable UPC-E Extend”:** Extend UPC-E barcodes to make them compatible in length to UPC-A.



0403110

**\*\* 【Disable UPC-E Extend】**



0403120

**【Enable UPC-E Extend】**



0006000

**\*\* 【Exit Setup】**





0006010

**【Enter Setup】**

## UPC-A

### Restore Factory Defaults



0404000

**\*\* 【Restore the Factory Defaults of UPC-A】**

### Enable/Disable UPC-A



0404020

**\*\* 【Enable UPC-A】**



0404010

**【Disable UPC-A】**



If the scanner fails to identify UPC-A barcodes, you may first try this solution by scanning the **Enter Setup** barcode and then **Enable UPC-A** barcode.

### Transmit Check Digit

UPC-A is 12 digits in length with the last one as its check digit used to verify the integrity of the data.



0404040

**\*\* 【Transmit UPC-A Check Digit】**



0404030

**【Do Not Transmit UPC-A Check Digit】**



0006000

**\*\* 【Exit Setup】**



**【Enter Setup】**

## 2-Digit Add-On Code

A UPC-A barcode can be augmented with a two-digit add-on code to form a new one. In the example below, the part surrounded by blue dotted line is a UPC-A barcode while the part circled by red dotted line is a two-digit add-on code.



**\*\* 【Disable 2-Digit Add-On Code】**



**【Enable 2-Digit Add-On Code】**



**Disable 2-Digit Add-On Code:** The scanner decodes UPC-A and ignores the add-on code when presented with a UPC-A plus 2-digit add-on barcode. It can also decode UPC-A barcodes without 2-digit add-on codes.

**Enable 2-Digit Add-On Code:** The scanner decodes a mix of UPC-A barcodes with and without 2-digit add-on codes.



**\*\* 【Exit Setup】**



0006010

**【Enter Setup】**

## 5-Digit Add-On Code

A UPC-A barcode can be augmented with a five-digit add-on code to form a new one. In the example below, the part surrounded by blue dotted line is a UPC-A barcode while the part circled by red dotted line is a five-digit add-on code.



0404070

**\*\* 【Disable 5-Digit Add-On Code】**



0404080

**【Enable 5-Digit Add-On Code】**



**Disable 5-Digit Add-On Code:** The scanner decodes UPC-A and ignores the add-on code when presented with a UPC-A plus 5-digit add-on barcode. It can also decode UPC-A barcodes without 5-digit add-on codes.

**Enable 5-Digit Add-On Code:** The scanner decodes a mix of UPC-A barcodes with and without 5-digit add-on codes.



0006000

**\*\* 【Exit Setup】**



0006010

**【Enter Setup】**

### Add-On Code Required



0404110

**【UPC-A Add-On Code Required】**



0404120

**\*\* 【UPC-A Add-On Code Not Required】**

### Transmit Preamble Character “0”

The preamble character “0” is part of the UPC-A barcode.



0404090

**\*\* 【Do Not Transmit Preamble Character “0”】**



0404100

**【Transmit Preamble Character “0”】**



The preamble character “0” usually does not appear in printed UPC-A barcodes.



0006000

**\*\* 【Exit Setup】**



0006010

**【Enter Setup】**

---

## Interleaved 2 of 5

### Restore Factory Defaults



0405000

**\*\* 【Restore the Factory Defaults of Interleaved 2 of 5】**

### Enable/Disable Interleaved 2 of 5



0405020

**\*\* 【Enable Interleaved 2 of 5】**



0405010

**【Disable Interleaved 2 of 5】**



If the scanner fails to identify Interleaved 2 of 5 barcodes, you may first try this solution by scanning the **Enter Setup** barcode and then **Enable Interleaved 2 of 5** barcode.



0006000

**\*\* 【Exit Setup】**



0006010

**【Enter Setup】**

### Set Length Range for Interleaved 2 of 5

The scanner can be configured to only decode Interleaved 2 of 5 barcodes with lengths that fall between (inclusive) the minimum and maximum lengths. To accomplish it, you need to set the minimum and maximum lengths.

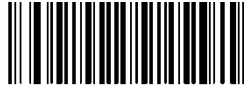

0405030

**【Set the Minimum Length (Default: 6)】**



0405040

**【Set the Maximum Length (Default: 127)】**



If minimum length is set to be greater than maximum length, the scanner only decodes Interleaved 2 of 5 barcodes with either the minimum or maximum length. If minimum length is same as maximum length, only Interleaved 2 of 5 barcodes with that length are to be decoded.



**Set the scanner to decode Interleaved 2 of 5 barcodes containing between 8 and 12 characters:**

1. Scan the **Enter Setup** barcode.
2. Scan the **Set the Minimum Length** barcode.
3. Scan the numeric barcode "8".
4. Scan the **Save** barcode.
5. Scan the **Set the Maximum Length** barcode.
6. Scan the numeric barcode "1".
7. Scan the numeric barcode "2".
8. Scan the **Save** barcode.
9. Scan the **Exit Setup** barcode.



0006000

**\*\*【Exit Setup】**



0006010

**【Enter Setup】**

## Check Digit Verification

A check digit is optional for Interleaved 2 of 5 and can be added as the last digit. It is a calculated value used to verify the integrity of the data.

- ◇ **Disable:** The scanner transmits Interleaved 2 of 5 barcodes as is.
- ◇ **Do Not Transmit Check Digit After Verification:** The scanner checks the integrity of all Interleaved 2 of 5 barcodes to verify that the data complies with the check digit algorithm. Barcodes passing the check will be transmitted except the last digit, whereas those failing it will not be transmitted.
- ◇ **Transmit Check Digit After Verification:** The scanner checks the integrity of all Interleaved 2 of 5 barcodes to verify that the data complies with the check digit algorithm. Barcodes passing the check will be transmitted, whereas those failing it will not be transmitted.

Since Interleaved 2 of 5 must always have an even number of digits, a zero may need to be added as the first digit when the check digit is added. The check digit is automatically generated when making Interleaved 2 of 5 barcodes.



0405050

**【Disable】**



0405060

\*\* **【Do Not Transmit Check Digit After Verification】**



0405070

**【Transmit Check Digit After Verification】**



If the **Do Not Transmit Check Digit After Verification** option is enabled, Interleaved 2 of 5 barcodes with a length that is less than the configured minimum length after having the check digit excluded will not be decoded. (For example, when the **Do Not Transmit Check Digit After Verification** option is enabled and the minimum length is set to 4, Interleaved 2 of 5 barcodes with a total length of 4 characters including the check digit cannot be read.)



0006000

\*\* **【Exit Setup】**



0006010

**【Enter Setup】**

## ITF-14

ITF-14 is a special kind of Interleaved 2 of 5 with a length of 14 characters and the last character as the check character. By default, ITF-14 is disabled.

ITF-14 priority principle: For the Interleaved 2 of 5 barcodes with a length of 14 characters and the last character as the check character, the ITF-14 configurations shall take precedence over the Interleaved 2 of 5 settings.



0405260

**【Restore the Factory Defaults of ITF-14】**



0405080

**\*\* 【Disable ITF-14】**



0405090

**【Enable ITF-14, Do Not Transmit Check Digit】**



0405100

**【Enable ITF-14, Transmit Check Digit】**



An example of the ITF-14 priority principle: when ITF-14 is enabled and Interleaved 2 of 5 is disabled, the scanner only decodes Interleaved 2 of 5 barcodes with a length of 14 characters and the last character as the check character.



0006000

**\*\* 【Exit Setup】**





0006010

**【Enter Setup】**

## ITF-6

ITF-6 is a special kind of Interleaved 2 of 5 with a length of 6 characters and the last character as the check character. By default, ITF-6 is disabled.

ITF-6 priority principle: For the Interleaved 2 of 5 barcodes with a length of 6 characters and the last character as the check character, the ITF-6 configurations shall take precedence over the Interleaved 2 of 5 settings.



0405270

**【Restore the Factory Defaults of ITF-6】**



0405110

**\*\* 【Disable ITF-6】**



0405120

**【Enable ITF-6, Do Not Transmit Check Digit】**



0405130

**【Enable ITF-6, Transmit Check Digit】**



An example of the ITF-6 priority principle: when ITF-6 is enabled and Interleaved 2 of 5 is disabled, the scanner only decodes Interleaved 2 of 5 barcodes with a length of 6 characters and the last character as the check character.



0006000

**\*\* 【Exit Setup】**



0006010

**【Enter Setup】**

## Matrix 2 of 5

### Restore Factory Defaults



0406000

**\*\* 【Restore the Factory Defaults of Matrix 2 of 5】**

### Enable/Disable Matrix 2 of 5



0406020

**【Enable Matrix 2 of 5】**



0406010

**\*\* 【Disable Matrix 2 of 5】**



If the scanner fails to identify Matrix 2 of 5 barcodes, you may first try this solution by scanning the **Enter Setup** barcode and then **Enable Matrix 2 of 5** barcode.



0006000

**\*\* 【Exit Setup】**



0006010

**【Enter Setup】**

## Set Length Range for Matrix 2 of 5

The scanner can be configured to only decode Matrix 2 of 5 barcodes with lengths that fall between (inclusive) the minimum and maximum lengths. To accomplish it, you need to set the minimum and maximum lengths.



0406030

**【Set the Minimum Length (Default: 6)】**



0406040

**【Set the Maximum Length (Default: 127)】**



If minimum length is set to be greater than maximum length, the scanner only decodes Matrix 2 of 5 barcodes with either the minimum or maximum length. If minimum length is same as maximum length, only Matrix 2 of 5 barcodes with that length are to be decoded.

**E**  
*sample*

**Set the scanner to decode Matrix 2 of 5 barcodes containing between 8 and 12 characters:**

1. Scan the **Enter Setup** barcode.
2. Scan the **Set the Minimum Length** barcode.
3. Scan the numeric barcode “8”.
4. Scan the **Save** barcode.
5. Scan the **Set the Maximum Length** barcode.
6. Scan the numeric barcode “1”.
7. Scan the numeric barcode “2”.
8. Scan the **Save** barcode.
9. Scan the **Exit Setup** barcode.



0006000

**\*\*【Exit Setup】**



**【Enter Setup】**

## Check Digit Verification

A check digit is optional for Matrix 2 of 5 and can be added as the last digit. It is a calculated value used to verify the integrity of the data.

- ◇ **Disable:** The scanner transmits Matrix 2 of 5 barcodes as is.
- ◇ **Do Not Transmit Check Digit After Verification:** The scanner checks the integrity of all Matrix 2 of 5 barcodes to verify that the data complies with the check digit algorithm. Barcodes passing the check will be transmitted except the last digit, whereas those failing it will not be transmitted.
- ◇ **Transmit Check Digit After Verification:** The scanner checks the integrity of all Matrix 2 of 5 barcodes to verify that the data complies with the check digit algorithm. Barcodes passing the check will be transmitted, whereas those failing it will not be transmitted.

Since Matrix 2 of 5 must always have an even number of digits, a zero may need to be added as the first digit when the check digit is added. The check digit is automatically generated when making Matrix 2 of 5 barcodes.



**【Disable】**



**\*\* 【Do Not Transmit Check Digit After Verification】**



**【Transmit Check Digit After Verification】**



If the **Do Not Transmit Check Digit After Verification** option is enabled, Matrix 2 of 5 barcodes with a length that is less than the configured minimum length after having the check digit excluded will not be decoded. (For example, when the **Do Not Transmit Check Digit After Verification** option is enabled and the minimum length is set to 4, Matrix 2 of 5 barcodes with a total length of 4 characters including the check digit cannot be read.)



**\*\* 【Exit Setup】**



0006010

**【Enter Setup】**

## Code 39

### Restore Factory Defaults



0408000

**\*\* 【Restore the Factory Defaults of Code 39】**

### Enable/Disable Code 39



0408020

**\*\* 【Enable Code 39】**



0408010

**【Disable Code 39】**



If the scanner fails to identify Code 39 barcodes, you may first try this solution by scanning the **Enter Setup** barcode and then **Enable Code 39** barcode.

### Transmit Start/Stop Character

Code 39 uses an asterisk (\*) for both the start and the stop characters. You can choose whether or not to transmit the start/stop characters by scanning the appropriate barcode below.



0408090

**【Transmit Start/Stop Character】**



0408080

**\*\* 【Do Not Transmit Start/Stop Character】**



0006000

**\*\* 【Exit Setup】**



0006010

**【Enter Setup】**

### Set Length Range for Code 39

The scanner can be configured to only decode Code 39 barcodes with lengths that fall between (inclusive) the minimum and maximum lengths. To accomplish it, you need to set the minimum and maximum lengths.



0408030

**【Set the Minimum Length (Default: 4)】**



0408040

**【Set the Maximum Length (Default: 127)】**



If minimum length is set to be greater than maximum length, the scanner only decodes Code 39 barcodes with either the minimum or maximum length. If minimum length is same as maximum length, only Code 39 barcodes with that length are to be decoded.



**Set the scanner to decode Code 39 barcodes containing between 8 and 12 characters:**

1. Scan the **Enter Setup** barcode.
2. Scan the **Set the Minimum Length** barcode.
3. Scan the numeric barcode "8".
4. Scan the **Save** barcode.
5. Scan the **Set the Maximum Length** barcode.
6. Scan the numeric barcode "1".
7. Scan the numeric barcode "2".
8. Scan the **Save** barcode.
9. Scan the **Exit Setup** barcode.



0006000

**\*\*【Exit Setup】**



0006010

**【Enter Setup】**

## Check Digit Verification

A check digit is optional for Code 39 and can be added as the last digit. It is a calculated value used to verify the integrity of the data.

- ◇ **Disable:** The scanner transmits Code 39 barcodes as is.
- ◇ **Do Not Transmit Check Digit After Verification:** The scanner checks the integrity of all Code 39 barcodes to verify that the data complies with the check digit algorithm. Barcodes passing the check will be transmitted except the last digit, whereas those failing it will not be transmitted.
- ◇ **Transmit Check Digit After Verification:** The scanner checks the integrity of all Code 39 barcodes to verify that the data complies with the check digit algorithm. Barcodes passing the check will be transmitted, whereas those failing it will not be transmitted.



0408050

**\*\* 【Disable】**



0408060

**【Do Not Transmit Check Digit After Verification】**



0408070

**【Transmit Check Digit After Verification】**



If the **Do Not Transmit Check Digit After Verification** option is enabled, Code 39 barcodes with a length that is less than the configured minimum length after having the check digit excluded will not be decoded. (For example, when the **Do Not Transmit Check Digit After Verification** option is enabled and the minimum length is set to 4, Code 39 barcodes with a total length of 4 characters including the check digit cannot be read.)



0006000

**\*\* 【Exit Setup】**



0006010

**【Enter Setup】**

---

### **Enable/Disable Code 39 Full ASCII**

You can enable or disable your scanner's ability to identify all ASCII characters by scanning the appropriate barcode below.



0408100

**【Disable Code 39 Full ASCII】**



0408110

**\*\* 【Enable Code 39 Full ASCII】**



0006000

**\*\* 【Exit Setup】**





0006010

**【Enter Setup】**

---

## Codabar

### Restore Factory Defaults



0409000

**\*\* 【Restore the Factory Defaults of Codabar】**

### Enable/Disable Codabar



0409020

**\*\* 【Enable Codabar】**



0409010

**【Disable Codabar】**



If the scanner fails to identify Codabar barcodes, you may first try this solution by scanning the **Enter Setup** barcode and then **Enable Codabar** barcode.



0006000

**\*\* 【Exit Setup】**



0006010

**【Enter Setup】**

### Set Length Range for Codabar

The scanner can be configured to only decode Codabar barcodes with lengths that fall between (inclusive) the minimum and maximum lengths. To accomplish it, you need to set the minimum and maximum lengths.

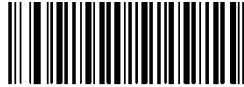

0409030

**【Set the Minimum Length (Default: 1)】**



0409040

**【Set the Maximum Length (Default: 127)】**



If minimum length is set to be greater than maximum length, the scanner only decodes Codabar barcodes with either the minimum or maximum length. If minimum length is same as maximum length, only Codabar barcodes with that length are to be decoded.



**Set the scanner to decode Codabar barcodes containing between 8 and 12 characters:**

1. Scan the **Enter Setup** barcode.
2. Scan the **Set the Minimum Length** barcode.
3. Scan the numeric barcode "8".
4. Scan the **Save** barcode.
5. Scan the **Set the Maximum Length** barcode.
6. Scan the numeric barcode "1".
7. Scan the numeric barcode "2".
8. Scan the **Save** barcode.
9. Scan the **Exit Setup** barcode.



0006000

**\*\*【Exit Setup】**



0006010

**【Enter Setup】**

## Check Digit Verification

A check digit is optional for Codabar and can be added as the last digit. It is a calculated value used to verify the integrity of the data.

- ◇ **Disable:** The scanner transmits Codabar barcodes as is.
- ◇ **Do Not Transmit Check Digit After Verification:** The scanner checks the integrity of all Codabar barcodes to verify that the data complies with the check digit algorithm. Barcodes passing the check will be transmitted except the last digit, whereas those failing it will not be transmitted.
- ◇ **Transmit Check Digit After Verification:** The scanner checks the integrity of all Codabar barcodes to verify that the data complies with the check digit algorithm. Barcodes passing the check will be transmitted, whereas those failing it will not be transmitted.



0409050

**\*\* 【Disable】**



0409060

**【Do Not Transmit Check Digit After Verification】**



0409070

**【Transmit Check Digit After Verification】**



If the **Do Not Transmit Check Digit After Verification** option is enabled, Codabar barcodes with a length that is less than the configured minimum length after having the check digit excluded will not be decoded. (For example, when the **Do Not Transmit Check Digit After Verification** option is enabled and the minimum length is set to 4, Codabar barcodes with a total length of 4 characters including the check digit cannot be read.)



0006000

**\*\* 【Exit Setup】**



0006010

**【Enter Setup】**

---

### Start/Stop Character

You can set the start/stop characters and choose whether or not to transmit the start/stop characters by scanning the appropriate barcode below.



0409090

**【Transmit Start/Stop Character】**



0409080

**\*\* 【Do Not Transmit Start/Stop Character】**



0409100

**\*\* 【ABCD/ABCD as the Start/Stop Character】**



0409120

**\*\* 【Start/Stop Character in Uppercase】**



0409110

**【ABCD/TN\*E as the Start/Stop Character】**



0409130

**【Start/Stop Character in Lowercase】**



0006000

**\*\* 【Exit Setup】**



0006010

**【Enter Setup】**

---

## Code 93

### Restore Factory Defaults



0410000

**\*\* 【Restore the Factory Defaults of Code 93】**

### Enable/Disable Code 93



0410010

**【Disable Code 93】**



0410020

**\*\* 【Enable Code 93】**



If the scanner fails to identify Code 93 barcodes, you may first try this solution by scanning the **Enter Setup** barcode and then **Enable Code 93** barcode.



0006000

**\*\* 【Exit Setup】**



0006010

**【Enter Setup】**

### Set Length Range for Code 93

The scanner can be configured to only decode Code 93 barcodes with lengths that fall between (inclusive) the minimum and maximum lengths. To accomplish it, you need to set the minimum and maximum lengths.



0410030

**【Set the Minimum Length (Default: 3)】**



0410040

**【Set the Maximum Length (Default: 127)】**



If minimum length is set to be greater than maximum length, the scanner only decodes Code 93 barcodes with either the minimum or maximum length. If minimum length is same as maximum length, only Code 93 barcodes with that length are to be decoded.

**E**  
*sample*

**Set the scanner to decode Code 93 barcodes containing between 8 and 12 characters:**

1. Scan the **Enter Setup** barcode.
2. Scan the **Set the Minimum Length** barcode.
3. Scan the numeric barcode "8".
4. Scan the **Save** barcode.
5. Scan the **Set the Maximum Length** barcode.
6. Scan the numeric barcode "1".
7. Scan the numeric barcode "2".
8. Scan the **Save** barcode.
9. Scan the **Exit Setup** barcode.



0006000

**\*\*【Exit Setup】**



0006010

**【Enter Setup】**

## Check Digit Verification

Check digits are optional for Code 93 and can be added as the last two digits, which are calculated values used to verify the integrity of the data.

- ◇ **Disable:** The scanner transmits Code 93 barcodes as is.
- ◇ **Do Not Transmit Check Digit After Verification:** The scanner checks the integrity of all Code 93 barcodes to verify that the data complies with the check digit algorithm. Barcodes passing the checks will be transmitted except the last two digits, whereas those failing them will not be transmitted.
- ◇ **Transmit Check Digit After Verification:** The scanner checks the integrity of all Code 93 barcodes to verify that the data complies with the check digit algorithm. Barcodes passing the checks will be transmitted, whereas those failing them will not be transmitted.



0410050

**【Disable】**



0410060

**\*\* 【Do Not Transmit Check Digit After Verification】**



0410070

**【Transmit Check Digit After Verification】**



If the **Do Not Transmit Check Digit After Verification** option is enabled, Code 93 barcodes with a length that is less than the configured minimum length after having the two check digits excluded will not be decoded. (For example, when the **Do Not Transmit Check Digit After Verification** option is enabled and the minimum length is set to 4, Code 93 barcodes with a total length of 4 characters including the two check digits cannot be read.)



0006000

**\*\* 【Exit Setup】**



0006010

**【Enter Setup】**

## GS1 Databar(RSS)

### Restore Factory Defaults



0413000

**\*\* 【Restore the Factory Defaults of GS1 Databar】**

### Enable/Disable GS1 Databar



0413020

**\*\* 【Enable GS1 Databar】**



0413010

**【Disable GS1 Databar】**



If the scanner fails to identify GS1 Databar barcodes, you may first try this solution by scanning the **Enter Setup** barcode and then **Enable GS1 Databar** barcode.

### Transmit Application Identifier “01”



0413060

**\*\* 【Transmit Application Identifier “01”】**



0413050

**【Do Not Transmit Application Identifier “01”】**



0006000

**\*\* 【Exit Setup】**





0006010

**【Enter Setup】**

---

## Code 11

### Restore Factory Defaults



0415000

**\*\* 【Restore the Factory Defaults of Code 11】**

### Enable/Disable Code 11



0415020

**\*\* 【Enable Code 11】**



0415010

**【Disable Code 11】**



If the scanner fails to identify Code 11 barcodes, you may first try this solution by scanning the **Enter Setup** barcode and then **Enable Code 11** barcode.



0006000

**\*\* 【Exit Setup】**



**【Enter Setup】**

### Set Length Range for Code 11

The scanner can be configured to only decode Code 11 barcodes with lengths that fall between (inclusive) the minimum and maximum lengths. To accomplish it, you need to set the minimum and maximum lengths.



**【Set the Minimum Length (Default: 2)】**



**【Set the Maximum Length (Default: 127)】**



If minimum length is set to be greater than maximum length, the scanner only decodes Code 11 barcodes with either the minimum or maximum length. If minimum length is same as maximum length, only Code 11 barcodes with that length are to be decoded.

**E**  
*xample*

**Set the scanner to decode Code 11 barcodes containing between 8 and 12 characters:**

1. Scan the **Enter Setup** barcode.
2. Scan the **Set the Minimum Length** barcode.
3. Scan the numeric barcode "8".
4. Scan the **Save** barcode.
5. Scan the **Set the Maximum Length** barcode.
6. Scan the numeric barcode "1".
7. Scan the numeric barcode "2".
8. Scan the **Save** barcode.
9. Scan the **Exit Setup** barcode.



**\*\* 【Exit Setup】**



0006010

**【Enter Setup】**

## Check Digit Verification

Check digits are optional for Code 11 and can be added as the last one or two digits, which are calculated values used to verify the integrity of the data.

If the **Disable** option is enabled, the scanner transmits Code 11 barcodes as is.



**【Disable】**



**【One Check Digit, MOD11 (Len<=10)】**  
**【Two Check Digits, MOD11/MOD11(Len>10)】**



**\*\* 【One Check Digit, MOD11】**



**【One Check Digit, MOD11 (Len<=10)】**  
**【Two Check Digits, MOD11/MOD9 (Len>10)】**



**【Two Check Digits, MOD11/MOD11】**



**\*\* 【Do Not Transmit Check Digit】**



**【Two Check Digits, MOD11/MOD9】**



**【Transmit Check Digit】**



If you select a check digit algorithm and the **Do Not Transmit Check Digit** option, Code 11 barcodes with a length that is less than the configured minimum length after having the check digit(s) excluded will not be decoded. (For example, when the **One Check Digit, MOD11** and **Do Not Transmit Check Digit** options are enabled and the minimum length is set to 4, Code 11 barcodes with a total length of 4 characters including the check digit cannot be read.)



0006000

**\*\* 【Exit Setup】**



0006010

**【Enter Setup】**

---

## ISSN

### Restore Factory Defaults



0421000

**【Restore the Factory Defaults of ISSN】**

### Enable/Disable ISSN



0421020

**【Enable ISSN】**



0421010

**\*\* 【Disable ISSN】**



If the scanner fails to identify ISSN barcodes, you may first try this solution by scanning the **Enter Setup** barcode and then **Enable ISSN** barcode.



0006000

**\*\* 【Exit Setup】**



0006010

**【Enter Setup】**

### Add-On Code



0421030

**【Enable 2-Digit Add-On Code】**



0421040

**\*\* 【Disable 2-Digit Add-On Code】**



0421050

**【Enable 5-Digit Add-On Code】**



0421060

**\*\* 【Disable 5-Digit Add-On Code】**

**Enable 2-Digit Add-On Code/ Enable 5-Digit Add-On Code:** The scanner decodes a mix of ISSN barcodes with and without 2-digit/5-digit add-on codes.

**Disable 2-Digit Add-On Code/ Disable 5-Digit Add-On Code:** The scanner decodes ISSN and ignores the add-on code when presented with an ISSN plus add-on barcode. It can also decode ISSN barcodes without add-on codes.

### Add-On Code Required



0421070

**【ISSN Add-On Code Required】**



0421080

**\*\* 【ISSN Add-On Code Not Required】**



0006000

**\*\* 【Exit Setup】**



0006010

**【Enter Setup】**

## ISBN

### Restore Factory Defaults



0416000

**\*\* 【Restore the Factory Defaults of ISBN】**

### Enable/Disable ISBN



0416020

**【Enable ISBN】**



0416010

**\*\* 【Disable ISBN】**



If the scanner fails to identify ISBN barcodes, you may first try this solution by scanning the **Enter Setup** barcode and then **Enable ISBN** barcode.

### Set ISBN Format



0416030

**\*\* 【ISBN-13】**



0416040

**【ISBN-10】**



0006000

**\*\* 【Exit Setup】**



0006010

**【Enter Setup】**

---

## Industrial 25

### Restore Factory Defaults



0417000

**\*\* 【Restore the Factory Defaults of Industrial 25】**

### Enable/Disable Industrial 25



0417020

**\*\* 【Enable Industrial 25】**



0417010

**【Disable Industrial 25】**



If the scanner fails to identify Industrial 25 barcodes, you may first try this solution by scanning the **Enter Setup** barcode and then **Enable Industrial 25** barcode.



0006000

**\*\* 【Exit Setup】**



**【Enter Setup】**

### Set Length Range for Industrial 25

The scanner can be configured to only decode Industrial 25 barcodes with lengths that fall between (inclusive) the minimum and maximum lengths. To accomplish it, you need to set the minimum and maximum lengths.



**【Set the Minimum Length (Default: 6)】**



**【Set the Maximum Length (Default: 127)】**



If minimum length is set to be greater than maximum length, the scanner only decodes Industrial 25 barcodes with either the minimum or maximum length. If minimum length is same as maximum length, only Industrial 25 barcodes with that length are to be decoded.

**E**  
*example*

**Set the scanner to decode Industrial 25 barcodes containing between 8 and 12 characters:**

1. Scan the **Enter Setup** barcode.
2. Scan the **Set the Minimum Length** barcode.
3. Scan the numeric barcode "8".
4. Scan the **Save** barcode.
5. Scan the **Set the Maximum Length** barcode.
6. Scan the numeric barcode "1".
7. Scan the numeric barcode "2".
8. Scan the **Save** barcode.
9. Scan the **Exit Setup** barcode.



**\*\* 【Exit Setup】**





0006010

**【Enter Setup】**

## Check Digit Verification

A check digit is optional for Industrial 25 and can be added as the last digit. It is a calculated value used to verify the integrity of the data.

- ◇ **Disable:** The scanner transmits Industrial 25 barcodes as is.
- ◇ **Do Not Transmit Check Digit After Verification:** The scanner checks the integrity of all Industrial 25 barcodes to verify that the data complies with the check digit algorithm. Barcodes passing the check will be transmitted except the last digit, whereas those failing it will not be transmitted.
- ◇ **Transmit Check Digit After Verification:** The scanner checks the integrity of all Industrial 25 barcodes to verify that the data complies with the check digit algorithm. Barcodes passing the check will be transmitted, whereas those failing it will not be transmitted.



0417050

**\*\* 【Disable】**



0417060

**【Do Not Transmit Check Digit After Verification】**



0417070

**【Transmit Check Digit After Verification】**



If the **Do Not Transmit Check Digit After Verification** option is enabled, Industrial 25 barcodes with a length that is less than the configured minimum length after having the check digit excluded will not be decoded. (For example, when the **Do Not Transmit Check Digit After Verification** option is enabled and the minimum length is set to 4, Industrial 25 barcodes with a total length of 4 characters including the check digit cannot be read.)



0006000

**\*\* 【Exit Setup】**



0006010

**【Enter Setup】**

---

## Standard 25 (IATA 2 of 5)

### Restore Factory Defaults



0418000

**\*\* 【Restore the Factory Defaults of Standard 25】**

### Enable/Disable Standard 25



0418020

**\*\* 【Enable Standard 25】**



0418010

**【Disable Standard 25】**



If the scanner fails to identify Standard 25 barcodes, you may first try this solution by scanning the **Enter Setup** barcode and then **Enable Standard 25** barcode.



0006000

**\*\* 【Exit Setup】**



0006010

**【Enter Setup】**

---

## Set Length Range for Standard 25

The scanner can be configured to only decode Standard 25 barcodes with lengths that fall between (inclusive) the minimum and maximum lengths. To accomplish it, you need to set the minimum and maximum lengths.



0418030

**【Set the Minimum Length (Default: 6)】**



0418040

**【Set the Maximum Length (Default: 127)】**



If minimum length is set to be greater than maximum length, the scanner only decodes Standard 25 barcodes with either the minimum or maximum length. If minimum length is same as maximum length, only Standard 25 barcodes with that length are to be decoded.



**Set the scanner to decode Standard 25 barcodes containing between 8 and 12 characters:**

1. Scan the **Enter Setup** barcode.
2. Scan the **Set the Minimum Length** barcode.
3. Scan the numeric barcode “8”.
4. Scan the **Save** barcode.
5. Scan the **Set the Maximum Length** barcode.
6. Scan the numeric barcode “1”.
7. Scan the numeric barcode “2”.
8. Scan the **Save** barcode.
9. Scan the **Exit Setup** barcode.



0006000

**\*\*【Exit Setup】**



0006010

**【Enter Setup】**

## Check Digit Verification

A check digit is optional for Standard 25 and can be added as the last digit. It is a calculated value used to verify the integrity of the data.

- ◇ **Disable:** The scanner transmits Standard 25 barcodes as is.
- ◇ **Do Not Transmit Check Digit After Verification:** The scanner checks the integrity of all Standard 25 barcodes to verify that the data complies with the check digit algorithm. Barcodes passing the check will be transmitted except the last digit, whereas those failing it will not be transmitted.
- ◇ **Transmit Check Digit After Verification:** The scanner checks the integrity of all Standard 25 barcodes to verify that the data complies with the check digit algorithm. Barcodes passing the check will be transmitted, whereas those failing it will not be transmitted.



0418050

**\*\* 【Disable】**



0418060

**【Do Not Transmit Check Digit After Verification】**



0418070

**【Transmit Check Digit After Verification】**



If the **Do Not Transmit Check Digit After Verification** option is enabled, Standard 25 barcodes with a length that is less than the configured minimum length after having the check digit excluded will not be decoded. (For example, when the **Do Not Transmit Check Digit After Verification** option is enabled and the minimum length is set to 4, Standard 25 barcodes with a total length of 4 characters including the check digit cannot be read.)



0006000

**\*\* 【Exit Setup】**



0006010

**【Enter Setup】**

---

## Plessey

### Restore Factory Defaults



0419000

**\*\* 【Restore the Factory Defaults of Plessey】**

### Enable/Disable Plessey



0419020

**【Enable Plessey】**



0419010

**\*\* 【Disable Plessey】**



If the scanner fails to identify Plessey barcodes, you may first try this solution by scanning the **Enter Setup** barcode and then **Enable Plessey** barcode.



0006000

**\*\* 【Exit Setup】**



0006010

**【Enter Setup】**

## Set Length Range for Plessey

The scanner can be configured to only decode Plessey barcodes with lengths that fall between (inclusive) the minimum and maximum lengths. To accomplish it, you need to set the minimum and maximum lengths.



0419030

**【Set the Minimum Length (Default: 1)】**



0419040

**【Set the Maximum Length (Default: 127)】**



If minimum length is set to be greater than maximum length, the scanner only decodes Plessey barcodes with either the minimum or maximum length. If minimum length is same as maximum length, only Plessey barcodes with that length are to be decoded.



**Set the scanner to decode Plessey barcodes containing between 8 and 12 characters:**

1. Scan the **Enter Setup** barcode.
2. Scan the **Set the Minimum Length** barcode.
3. Scan the numeric barcode "8".
4. Scan the **Save** barcode.
5. Scan the **Set the Maximum Length** barcode.
6. Scan the numeric barcode "1".
7. Scan the numeric barcode "2".
8. Scan the **Save** barcode.
9. Scan the **Exit Setup** barcode.



0006000

**\*\*【Exit Setup】**



0006010

**【Enter Setup】**

## Check Digit Verification

Check digits are optional for Plessey and can be added as the last two digits, which are calculated values used to verify the integrity of the data.

- ◇ **Disable:** The scanner transmits Plessey barcodes as is.
- ◇ **Do Not Transmit Check Digit After Verification:** The scanner checks the integrity of all Plessey barcodes to verify that the data complies with the check digit algorithm. Barcodes passing the checks will be transmitted except the last two digits, whereas those failing them will not be transmitted.
- ◇ **Transmit Check Digit After Verification:** The scanner checks the integrity of all Plessey barcodes to verify that the data complies with the check digit algorithm. Barcodes passing the checks will be transmitted, whereas those failing them will not be transmitted.



0419050

**\*\* 【Disable】**



0419060

**【Do Not Transmit Check Digit After Verification】**



0419070

**【Transmit Check Digit After Verification】**



If the **Do Not Transmit Check Digit After Verification** option is enabled, Plessey barcodes with a length that is less than the configured minimum length after having the check digits excluded will not be decoded. (For example, when the **Do Not Transmit Check Digit After Verification** option is enabled and the minimum length is set to 4, Plessey barcodes with a total length of 4 characters including the check digits cannot be read.)



0006000

**\*\* 【Exit Setup】**



0006010

**【Enter Setup】**

---

## MSI-Plessey

### Restore Factory Defaults



0420000

**\*\* 【Restore the Factory Defaults of MSI-Plessey】**

### Enable/Disable MSI-Plessey



0420020

**【Enable MSI-Plessey】**



0420010

**\*\* 【Disable MSI-Plessey】**



If the scanner fails to identify MSI-Plessey barcodes, you may first try this solution by scanning the **Enter Setup** barcode and then **Enable MSI-Plessey** barcode.



0006000

**\*\* 【Exit Setup】**





0006010

**【Enter Setup】**

## Set Length Range for MSI-Plessey

The scanner can be configured to only decode MSI-Plessey barcodes with lengths that fall between (inclusive) the minimum and maximum lengths. To accomplish it, you need to set the minimum and maximum lengths.



0420030

**【Set the Minimum Length (Default: 2)】**



0420040

**【Set the Maximum Length (Default: 127)】**



If minimum length is set to be greater than maximum length, the scanner only decodes MSI-Plessey barcodes with either the minimum or maximum length. If minimum length is same as maximum length, only MSI-Plessey barcodes with that length are to be decoded.



**Set the scanner to decode MSI-Plessey barcodes containing between 8 and 12 characters:**

1. Scan the **Enter Setup** barcode.
2. Scan the **Set the Minimum Length** barcode.
3. Scan the numeric barcode "8".
4. Scan the **Save** barcode.
5. Scan the **Set the Maximum Length** barcode.
6. Scan the numeric barcode "1".
7. Scan the numeric barcode "2".
8. Scan the **Save** barcode.
9. Scan the **Exit Setup** barcode.



0006000

**\*\*【Exit Setup】**



0006010

**【Enter Setup】**

## Check Digit Verification

Check digits are optional for MSI-Plessey and can be added as the last one or two digits, which are calculated values used to verify the integrity of the data.

If the **Disable** option is enabled, the scanner transmits MSI-Plessey barcodes as is.



0420050

\*\* **【Disable】**



0420080

**【Two Check Digits, MOD10/MOD11】**



0420060

**【One Check Digit, MOD10】**



0420090

\*\* **【Do Not Transmit Check Digit】**



0420070

**【Two Check Digits, MOD10/MOD10】**



0420100

**【Transmit Check Digit】**



If you select a check digit algorithm and the **Do Not Transmit Check Digit** option, MSI-Plessey barcodes with a length that is less than the configured minimum length after having the check digit(s) excluded will not be decoded. (For example, when the **One Check Digit, MOD10** and **Do Not Transmit Check Digit** options are enabled and the minimum length is set to 4, MSI-Plessey barcodes with a total length of 4 characters including the check digit cannot be read.)



0006000

\*\* **【Exit Setup】**



0006010

**【Enter Setup】**

---

## 2D Symbologies

### PDF417

#### Restore Factory Defaults



0501000

**\*\* 【Restore the Factory Defaults of PDF417】**

#### Enable/Disable PDF417



0501020

**\*\* 【Enable PDF417】**



0501010

**【Disable PDF417】**



If the scanner fails to identify PDF417 barcodes, you may first try this solution by scanning the **Enter Setup** barcode and then **Enable PDF417** barcode.



0006000

**\*\* 【Exit Setup】**



0006010

**【Enter Setup】**

### Set Length Range for PDF417

The scanner can be configured to only decode PDF417 barcodes with lengths that fall between (inclusive) the minimum and maximum lengths. To accomplish it, you need to set the minimum and maximum lengths.



0501030

**【Set the Minimum Length (Default: 1)】**



0501040

**【Set the Maximum Length (Default: 255)】**



Minimum length is not allowed to be greater than maximum length. If you only want to read PDF417 barcodes with a specific length, set both minimum and maximum lengths to be that desired length.

**E**  
*xample*

**Set the scanner to decode PDF417 barcodes containing between 8 and 12 bytes:**

1. Scan the **Enter Setup** barcode.
2. Scan the **Set the Minimum Length** barcode.
3. Scan the numeric barcode "8".
4. Scan the **Save** barcode.
5. Scan the **Set the Maximum Length** barcode.
6. Scan the numeric barcode "1".
7. Scan the numeric barcode "2".
8. Scan the **Save** barcode.
9. Scan the **Exit Setup** barcode.



0006000

**\*\*【Exit Setup】**



0006010

**【Enter Setup】**

---

## PDF417 Twin Code

PDF417 twin code is 2 PDF417 barcodes paralleled vertically or horizontally. Two of them must have the same direction and similar specifications and be placed closely together.

There are 3 options for reading PDF417 twin codes:

- ◇ **Single PDF417 Only:** Read either PDF417 code.
- ◇ **Twin PDF417 Only:** Read both PDF417 codes.
- ◇ **Both Single & Twin:** Read both PDF417 codes. If successful, transmit as twin PDF417 only. Otherwise, try single PDF417 only.



0501070

**\*\* 【Single PDF417 Only】**



0501080

**【Twin PDF417 Only】**



0501090

**【Both Single & Twin】**



0006000

**\*\* 【Exit Setup】**



0006010

**【Enter Setup】**

---

### Transmission Order of Twin Code

**Order 1:** Transmit the one containing more information first.

**Order 2:** Transmit the one containing less information first.



0501110

**\*\* 【Order 1】**



0501100

**【Order 2】**

### Character Encoding



0501350

**\*\* 【Default Character Encoding】**



0501351

**【UTF-8】**



0006000

**\*\* 【Exit Setup】**



0006010

**【Enter Setup】**

---

## QR Code

### Restore Factory Defaults



0502000

**\*\* 【Restore the Factory Defaults of QR Code】**

### Enable/Disable QR Code



0502020

**\*\* 【Enable QR Code】**



0502010

**【Disable QR Code】**



If the scanner fails to identify QR Code barcodes, you may first try this solution by scanning the **Enter Setup** barcode and then **Enable QR Code** barcode.



0006000

**\*\* 【Exit Setup】**



0006010

**【Enter Setup】**

## Set Length Range for QR Code

The scanner can be configured to only decode QR Code barcodes with lengths that fall between (inclusive) the minimum and maximum lengths. To accomplish it, you need to set the minimum and maximum lengths.



0502030

**【Set the Minimum Length (Default: 1)】**



0502040

**【Set the Maximum Length (Default: 7089)】**



Minimum length is not allowed to be greater than maximum length. If you only want to read QR Code barcodes with a specific length, set both minimum and maximum lengths to be that desired length.

**E**  
*xample*

**Set the scanner to decode QR Code barcodes containing between 8 and 12 bytes:**

1. Scan the **Enter Setup** barcode.
2. Scan the **Set the Minimum Length** barcode.
3. Scan the numeric barcode "8".
4. Scan the **Save** barcode.
5. Scan the **Set the Maximum Length** barcode.
6. Scan the numeric barcode "1".
7. Scan the numeric barcode "2".
8. Scan the **Save** barcode.
9. Scan the **Exit Setup** barcode.



0006000

**\*\*【Exit Setup】**





0006010

**【Enter Setup】**

---

## QR Twin Code

QR twin code is 2 QR barcodes paralleled vertically or horizontally. Two of them must have the same direction and similar specifications and be placed closely together.

There are 3 options for reading QR twin codes:

- ◇ **Single QR Only:** Read either QR code.
- ◇ **Twin QR Only:** Read both QR codes. Transmission order: left (upper) QR code followed by right (lower) QR code.
- ◇ **Both Single & Twin:** Read both QR codes. If successful, transmit as twin QR only. Otherwise, try single QR only.



0502070

**\*\* 【Single QR Only】**



0502090

**【Both Single & Twin】**



0502080

**【Twin QR Only】**



0006000

**\*\* 【Exit Setup】**



0006010

**【Enter Setup】**

---

## Micro QR



0502110

**\*\* 【Enable Micro QR】**



0502100

**【Disable Micro QR】**

## Character Encoding



0502160

**\*\* 【Default Character Encoding】**



0502161

**【UTF-8】**



0006000

**\*\* 【Exit Setup】**



0006010

**【Enter Setup】**

---

## Data Matrix

### Restore Factory Defaults



0504000

**\*\* 【Restore the Factory Defaults of Data Matrix】**

### Enable/Disable Data Matrix



0504020

**\*\* 【Enable Data Matrix】**



0504010

**【Disable Data Matrix】**



If the scanner fails to identify Data Matrix barcodes, you may first try this solution by scanning the **Enter Setup** barcode and then **Enable Data Matrix** barcode.



0006000

**\*\* 【Exit Setup】**



0006010

**【Enter Setup】**

---

### Set Length Range for Data Matrix

The scanner can be configured to only decode Data Matrix barcodes with lengths that fall between (inclusive) the minimum and maximum lengths. To accomplish it, you need to set the minimum and maximum lengths.



0504030

**【Set the Minimum Length (Default: 1)】**



0504040

**【Set the Maximum Length (Default: 255)】**



Minimum length is not allowed to be greater than maximum length. If you only want to read Data Matrix barcodes with a specific length, set both minimum and maximum lengths to be that desired length.



**Set the scanner to decode Data Matrix barcodes containing between 8 and 12 bytes:**

1. Scan the **Enter Setup** barcode.
2. Scan the **Set the Minimum Length** barcode.
3. Scan the numeric barcode "8".
4. Scan the **Save** barcode.
5. Scan the **Set the Maximum Length** barcode.
6. Scan the numeric barcode "1".
7. Scan the numeric barcode "2".
8. Scan the **Save** barcode.
9. Scan the **Exit Setup** barcode.



0006000

**\*\*【Exit Setup】**



0006010

**【Enter Setup】**

---

## Data Matrix Twin Code

Data Matrix twin code is 2 Data Matrix barcodes paralleled vertically or horizontally. Two of them must have the same direction and similar specifications and be placed closely together.

There are 3 options for reading Data Matrix twin codes:

- ◇ **Single Data Matrix Only:** Read either Data Matrix code.
- ◇ **Twin Data Matrix Only:** Read both Data Matrix codes. Transmission order: left (upper) Data Matrix code followed by right (lower) Data Matrix code.
- ◇ **Both Single & Twin:** Read both Data Matrix codes. If successful, transmit as twin Data Matrix only. Otherwise, try single Data Matrix only.



0504070

**\*\* 【Single Data Matrix Only】**



0504090

**【Both Single & Twin】**



0504080

**【Twin Data Matrix Only】**



0006000

**\*\* 【Exit Setup】**



0006010

**【Enter Setup】**

---

## Rectangular Barcode

Data Matrix has two formats:

Square barcodes having the same amount of modules in length and width: 10\*10, 12\*12.... 144\*144.

Rectangular barcodes having different amounts of models in length and width: 6\*16, 6\*14... 14\*22.



0504110

**\*\* 【Enable Rectangular Barcode】**



0504100

**【Disable Rectangular Barcode】**

## Mirror Image



0504331

**【Decode Mirror Images】**



0504330

**\*\* 【Do Not Decode Mirror Images】**

## Character Encoding



0504350

**\*\* 【Default Character Encoding】**



0504351

**【UTF-8】**



0006000

**\*\* 【Exit Setup】**



0006010

**【Enter Setup】**

## Chapter 8 Prefix & Suffix

### Introduction

In many applications, barcode data needs to be edited and distinguished from one another.

Usually AIM ID and Code ID can be used as identifiers, but in some special cases customized prefix and terminating character suffix like Carriage Return or Line Feed can also be the alternatives.

Data editing may include:

- ❖ Append AIM ID/Code ID/custom prefix before the scanned data
- ❖ Append custom suffix after the scanned data
- ❖ Append terminating character to the end of the data



0006000

**\*\*【Exit Setup】**



0006010

**【Enter Setup】**

---

## Global Settings

### Enable/Disable All Prefix/Suffix

**Disable All Prefix/Suffix:** Transmit scanned data with no prefix/suffix.

**Enable All Prefix/Suffix:** Allow to append Code ID prefix, AIM ID prefix, custom prefix/suffix and terminating character to the scanned data before the transmission.



0311000

**\*\* 【Disable All Prefix/Suffix】**



0311010

**【Enable All Prefix/Suffix】**

### Prefix Sequences

2 prefix sequence options are provided.



0317010

**【Code ID + Custom Prefix + AIM ID】**



0317040

**\*\* 【Custom Prefix + Code ID + AIM ID】**



0006000

**\*\* 【Exit Setup】**





0006010

**【Enter Setup】**

## Custom Prefix

### Enable/Disable Custom Prefix

If custom prefix is enabled, you are allowed to append before the scanned data a user-defined prefix that cannot exceed 10 characters. For example, if the custom prefix is “AB” and the scanned data is “123”, the Host will receive “AB123”.



0305000

**\*\* 【Disable Custom Prefix】**



0305010

**【Enable Custom Prefix】**

### Set Custom Prefix

To set a custom prefix, scan the **Set Custom Prefix** barcode, the numeric barcodes corresponding to the hexadecimal value of a desired prefix and the **Save** barcode.

**Note:** A custom prefix cannot exceed 10 characters.



0300000

**【Set Custom Prefix】**

**E**  
*example*

**Set the custom prefix to “CODE” (its hexadecimal value is 0x43/0x4F/0x44/0x45):**

1. Scan the **Enter Setup** barcode.
2. Scan the **Set Custom Prefix** barcode.
3. Scan the numeric barcodes “4”, “3”, “4”, “F”, “4”, “4”, “4” and “5”.
4. Scan the **Save** barcode.
5. Scan the **Enable Custom Prefix** barcode.
6. Scan the **Exit Setup** barcode.



0006000

**\*\* 【Exit Setup】**



0006010

**【Enter Setup】**

## AIM ID Prefix

AIM (Automatic Identification Manufacturers) ID defines symbology identifier (For the details, see the **AIM ID Table** section in **Appendix**). If AIM ID prefix is enabled, the scanner will add the symbology identifier before the scanned data after decoding.



0308000

**\*\* 【Disable AIM ID Prefix】**



0308030

**【Enable AIM ID Prefix】**



AIM ID is not user programmable.

## Code ID Prefix

Code ID can also be used to identify barcode type. Unlike AIM ID, Code ID is user programmable. Code ID can only consist of one or two English letters.



0307000

**\*\* 【Disable Code ID Prefix】**



0307010

**【Enable Code ID Prefix】**



0006000

**\*\* 【Exit Setup】**



0006010

**【Enter Setup】**

---

## Restore All Default Code IDs

For the information of default Code IDs, see the **Code ID Table** section in **Appendix**.



0307020

**【Restore All Default Code IDs】**

## Modify Code ID

See the examples below to learn how to modify a Code ID and restore the default Code IDs of all symbologies.

**E**  
*example*

### Set PDF417 Code ID to “p” (its hexadecimal value is 0x70):

1. Scan the **Enter Setup** barcode.
2. Scan the **Modify PDF417 Code ID** barcode.
3. Scan the numeric barcodes “7” and “0”.
4. Scan the **Save** barcode.
5. Scan the **Exit Setup** barcode.

### Restore the default Code IDs of all symbologies:

1. Scan the **Enter Setup** barcode.
2. Scan the **Restore All Default Code IDs** barcode.
3. Scan the **Exit Setup** barcode.



0006000

**\*\*【Exit Setup】**



0006010

**【Enter Setup】**

---



0005000

**【Modify PDF417 Code ID】**



0005030

**【Modify Data Matrix Code ID】**



0005010

**【Modify QR Code ID】**



0004020

**【Modify Code 128 Code ID】**



0004030

**【Modify GS1-128 Code ID】**



0004210

**【Modify AIM-128 Code ID】**



0004040

**【Modify EAN-8 Code ID】**



0004050

**【Modify EAN-13 Code ID】**



0004060

**【Modify UPC-E Code ID】**



0004070

**【Modify UPC-A Code ID】**



0006000

**\*\* 【Exit Setup】**



0006010

**【Enter Setup】**

---



0004240

**【Modify ISBN Code ID】**



0004230

**【Modify ISSN Code ID】**



0004130

**【Modify Code 39 Code ID】**



0004170

**【Modify Code 93 Code ID】**



0004080

**【Modify Interleaved 2 of 5 Code ID】**



0004090

**【Modify ITF-14 Code ID】**



0004100

**【Modify ITF-6 Code ID】**



0004150

**【Modify Codabar Code ID】**



0004250

**【Modify Industrial 25 Code ID】**



0004260

**【Modify Standard 25 Code ID】**



0006000

**\*\*【Exit Setup】**



0006010

**【Enter Setup】**

---



0004110

**【Modify Matrix 25Code ID】**



0004220

**【Modify COOP 25 Code ID】**



0004280

**【Modify Code 11 Code ID】**



0004270

**【Modify Plessey Code ID】**



0004290

**【Modify MSI/Plessey Code ID】**



0004310

**【Modify MSI/Plessey Code ID】**



0006000

**\*\*【Exit Setup】**



0006010

**【Enter Setup】**

## Custom Suffix

### Enable/Disable Custom Suffix

If custom suffix is enabled, you are allowed to append after the scanned data a user-defined suffix that cannot exceed 10 characters.

For example, if the custom suffix is “AB” and the scanned data is “123”, the Host will receive “123AB”.



0306000

**\*\* 【Disable Custom Suffix】**



0306010

**【Enable Custom Suffix】**

### Set Custom Suffix

To set a custom suffix, scan the **Set Custom Suffix** barcode, the numeric barcodes corresponding to the hexadecimal value of a desired suffix and the **Save** barcode.

**Note:** A custom suffix cannot exceed 10 characters.



0301000

**【Set Custom Suffix】**

**E**  
*sample*

**Set the custom suffix to “CODE” (its hexadecimal value is 0x43/0x4F/0x44/0x45):**

1. Scan the **Enter Setup** barcode.
2. Scan the **Set Custom Suffix** barcode.
3. Scan the numeric barcodes “4”, “3”, “4”, “F”, “4”, “4”, “4” and “5”.
4. Scan the **Save** barcode.
5. Scan the **Enable Custom Suffix** barcode.
6. Scan the **Exit Setup** barcode.



0006000

**\*\* 【Exit Setup】**



0006010

**【Enter Setup】**

---

## Terminating Character Suffix

### Enable/Disable Terminating Character Suffix

A terminating character such as carriage return (CR) or carriage return/line feed pair (CRLF) can only be used to mark the end of data, which means nothing can be added after it.



0309000

**\*\* 【Disable Terminating Character Suffix】**



0309010

**【Enable Terminating Character Suffix】**



0006000

**\*\* 【Exit Setup】**





0006010

【Enter Setup】

---

## Set Terminating Character Suffix

The scanner provides a shortcut for setting the terminating character suffix to CR (0x0D) or CRLF (0x0D,0x0A) by scanning the appropriate barcode below.



0310010

【Terminating Character CR (0x0D)】



0310020

【Terminating Character CRLF (0x0D,0x0A)】

To set a terminating character suffix, scan the **Set Terminating Character Suffix** barcode, the numeric barcodes corresponding to the hexadecimal value of a desired terminating character, and the **Save** barcode.

**Note:** A terminating character suffix cannot exceed 2 characters.



0310000

【Set Terminating Character Suffix】

**E**  
*sample*

**Set the terminating character suffix to “0A”:**

1. Scan the **Enter Setup** barcode.
2. Scan the **Set Terminating Character Suffix** barcode.
3. Scan the numeric barcodes “0” and “A”.
4. Scan the **Save** barcode.
5. Scan the **Enable Terminating Character Suffix** barcode.
6. Scan the **Exit Setup** barcode.



0006000

\*\* 【Exit Setup】

# Appendix

## Appendix 1: Factory Defaults Table

| Parameter                    | Factory Default | Remark |
|------------------------------|-----------------|--------|
| <b>Symbologies</b>           |                 |        |
| <b>Code 128</b>              |                 |        |
| Code 128                     | Enabled         |        |
| Maximum Length               | 127             |        |
| Minimum Length               | 1               |        |
| <b>AIM-128</b>               |                 |        |
| AIM-128                      | On              |        |
| Maximum Length               | 127             |        |
| Minimum Length               | 1               |        |
| <b>GS1-128 (UCC/EAN-128)</b> |                 |        |
| GS1-128                      | On              |        |
| Maximum Length               | 127             |        |
| Minimum Length               | 1               |        |
| <b>EAN-8</b>                 |                 |        |
| EAN-8                        | Enabled         |        |
| Check Digit                  | Transmit        |        |
| 2-Digit Add-On Code          | Disabled        |        |
| 5-Digit Add-On Code          | Disabled        |        |
| Add-On Code                  | Not required    |        |
| Extend to EAN-13             | Disabled        |        |
| <b>EAN-13</b>                |                 |        |
| EAN-13                       | Enabled         |        |
| Check Digit                  | Transmit        |        |
| 2-Digit Add-On Code          | Disabled        |        |

|                           |                 |                |
|---------------------------|-----------------|----------------|
| 5-Digit Add-On Code       | Disabled        |                |
| <b>UPC-E</b>              |                 |                |
| UPC-E                     | Enabled         |                |
| Check Digit               | Transmit        |                |
| 2-Digit Add-On Code       | Disabled        |                |
| 5-Digit Add-On Code       | Disabled        |                |
| Add-On Code               | Not required    |                |
| Extend to UPC-A           | Disabled        |                |
| System Character "0"      | Do not transmit |                |
| <b>UPC-A</b>              |                 |                |
| UPC-A                     | Enabled         |                |
| Check Digit               | Transmit        |                |
| 2-Digit Add-On Code       | Disabled        |                |
| 5-Digit Add-On Code       | Disabled        |                |
| Add-On Code               | Not required    |                |
| Preamble Character "0"    | Do not transmit |                |
| <b>Interleaved 2 of 5</b> |                 |                |
| Interleaved 2 of 5        | Enabled         |                |
| Check Digit Verification  | Disabled        |                |
| Check Digit               | Do not transmit |                |
| Maximum Length            | 127             |                |
| Minimum Length            | 6               | No less than 6 |
| Maximum Length            | Maximum Length  |                |
| <b>ITF-6</b>              |                 |                |
| ITF-6                     | Disabled        |                |
| <b>ITF-14</b>             |                 |                |
| ITF-14                    | Disabled        |                |
| <b>Matrix 2 of 5</b>      |                 |                |
| Matrix 2 of 5             | Disabled        |                |
| Check Digit Verification  | Enabled         |                |
| Check Digit               | Do not transmit |                |

|                                  |  |                |
|----------------------------------|--|----------------|
| Maximum Length                   | 127  |                |
| Minimum Length                   | 6  | No less than 6 |
| <b>Code 39</b>                   |  |                |
| Code 39                          | Enabled  |                |
| Check Digit Verification         | Disabled   |                |
| Start/Stop Character             | Do not transmit                                  |                |
| Code 39 Full ASCII               | Enabled  |                |
| Maximum Length                   | 127  |                |
| Minimum Length                   | 4  |                |
| <b>Codabar</b>                   |  |                |
| Codebar                          | Enabled  |                |
| Check Digit Verification         | Disabled   |                |
| Start/Stop Character             | ABCD/ABCD format<br>Uppercase<br>Do not transmit |                |
| Maximum Length                   | 127  |                |
| Minimum Length                   | 1  |                |
| <b>Code 93</b>                   |  |                |
| Code 93                          | Enabled  |                |
| Check Digit Verification         | Enabled  |                |
| Check Digit                      | Do not transmit                                  |                |
| Maximum Length                   | 127  |                |
| Minimum Length                   | 3  | No less than 3 |
| <b>UCC/EAN-128</b>               |  |                |
| UCC/EAN-128                      | Enabled  |                |
| <b>GS1 Databar</b>               |  |                |
| GS1 Databar                      | Enabled  |                |
| Application Identifier (AI) "01" | Transmit   |                |
| <b>Code 11</b>                   |  |                |
| Code 11                          | Enabled  |                |
| Check Digit                      | Do not transmit                                  |                |

|                          |                      |                |
|--------------------------|----------------------|----------------|
| Check Digit Verification | 1 Check Digit, MOD11 |                |
| Maximum Length           | 127                  |                |
| Minimum Length           | 2                    | No less than 2 |
| <b>ISSN</b>              |                      |                |
| ISBN                     | Disabled             |                |
| 2-Digit Add-On Code      | Disabled             |                |
| 5-Digit Add-On Code      | Disabled             |                |
| Add-On Code              | Not required         |                |
| <b>ISBN</b>              |                      |                |
| ISBN                     | Disabled             |                |
| ISBN Format              | ISBN-13              |                |
| <b>Industrial 25</b>     |                      |                |
| Industrial 25            | Enabled              |                |
| Check Digit Verification | Disabled             |                |
| Maximum Length           | 127                  |                |
| Minimum Length           | 6                    | No less than 6 |
| <b>Standard 25</b>       |                      |                |
| Standard 25              | Enabled              |                |
| Check Digit Verification | Disabled             |                |
| Maximum Length           | 127                  |                |
| Minimum Length           | 6                    | No less than 6 |
| <b>Plessey</b>           |                      |                |
| Plessey                  | Disabled             |                |
| Check Digit Verification | Disabled             |                |
| Maximum Length           | 127                  |                |
| Minimum Length           | 1                    | No less than 1 |
| <b>MSI-Plessey</b>       |                      |                |
| MSI-Plessey              | Disabled             |                |
| Check Digit Verification | Disabled             |                |
| Check Digit              | Do not transmit      |                |
| Maximum Length           | 127                  |                |

|                                 |                              |                |
|---------------------------------|------------------------------|----------------|
| Minimum Length                  | 2                            | No less than 2 |
| <b>PDF417</b>                   |                              |                |
| PDF417                          | Enabled                      |                |
| PDF417 Twin Code                | Read single PDF417 only      |                |
| Transmission Order of Twin Code | Order 1                      |                |
| Character Encoding              | Default Character Encoding   |                |
| Maximum Length                  | 255                          |                |
| Minimum Length                  | 1                            |                |
| <b>QR Code</b>                  |                              |                |
| QR Code                         | Enabled                      |                |
| QR Twin Code                    | Read single QR only          |                |
| Micro QR                        | Enabled                      |                |
| Character Encoding              | Default Character Encoding   |                |
| Maximum Length                  | 7089                         |                |
| Minimum Length                  | 1                            |                |
| <b>Data Matrix</b>              |                              |                |
| Data Matrix                     | Enabled                      |                |
| DM Twin Code                    | Read single Data Matrix only |                |
| Read Rectangular Barcode        | Enabled                      |                |
| Mirror Image                    | Do not decode                |                |
| Character Encoding              | Default Character Encoding   |                |
| Maximum Length                  | 255                          |                |
| Minimum Length                  | 1                            |                |

## Appendix 2: AIM ID Table

| Symbology             | AIM ID | Possible AIM ID Modifiers (m) |
|-----------------------|--------|-------------------------------|
| Code 128              | ]C0    |                               |
| UCC/EAN-128           | ]C1    |                               |
| EAN-8                 | ]E4    |                               |
| EAN-13                | ]E0    |                               |
| EAN-13 with Addon     | ]E3    |                               |
| UPC-E                 | ]E0    |                               |
| UPC-E with Addon      | ]E3    |                               |
| UPC-A                 | ]E0    |                               |
| UPC-A with Addon      | ]E3    |                               |
| Interleaved 2 of 5    | ]Im    | 0, 1, 3                       |
| ITF-6                 | ]Im    | 1, 3                          |
| ITF-14                | ]Im    | 1, 3                          |
| Matrix 2 of 5         | ]X0    |                               |
| Code 39               | ]Am    | 0, 1, 3, 4, 5, 7              |
| Codabar               | ]Fm    | 0, 2, 4                       |
| Code 93               | ]G0    |                               |
| Code 11               | ]Hm    | 0, 1, 3                       |
| ISBN                  | ]X0    |                               |
| Industrial 25         | ]S0    |                               |
| Standard 25           | ]R0    |                               |
| Plessey               | ]P0    |                               |
| MSI-Plessey           | ]Mm    | 0, 1                          |
| GS1 Databar           | ]e0    |                               |
| EAN•UCC Composite     | ]em    | 0-3                           |
| PDF417                | ]Lm    | 0-2                           |
| QR Code               | ]Qm    | 0-6                           |
| Aztec                 | ]zm    | 0-9, A-C                      |
| Data Matrix           | ]dm    | 0-6                           |
| Maxicode              | ]Um    | 0-3                           |
| Chinese Sensible Code | ]X0    |                               |

**Note:** “m” represents the AIM modifier character. Refer to ISO/IEC 15424:2008 Information technology – Automatic identification and data capture techniques – Data Carrier Identifiers (including Symbology Identifiers) for AIM modifier character details.

---

## Appendix 3: Code ID Table

| Symbology             | Code ID |
|-----------------------|---------|
| Code 128              | j       |
| UCC/EAN-128           | j       |
| EAN-8                 | d       |
| EAN-13                | d       |
| UPC-E                 | c       |
| UPC-A                 | c       |
| Interleaved 2 of 5    | e       |
| ITF-6                 | e       |
| ITF-14                | e       |
| Matrix 2 of 5         | v       |
| Code 39               | b       |
| Codabar               | a       |
| Code 93               | i       |
| Code 11               | H       |
| GS1 Databar           | R       |
| EAN•UCC Composite     | y       |
| ISBN                  | B       |
| Industrial 25         | l       |
| Standard 25           | f       |
| Plessey               | n       |
| MSI-Plessey           | m       |
| PDF417                | r       |
| QR Code               | s       |
| Aztec                 | z       |
| Data Matrix           | u       |
| Maxicode              | x       |
| Chinese Sensible Code | h       |



---

## Appendix 4: ASCII Table

| Hex | Dec | Char                          |
|-----|-----|-------------------------------|
| 00  | 0   | NUL (Null char.)              |
| 01  | 1   | SOH (Start of Header)         |
| 02  | 2   | STX (Start of Text)           |
| 03  | 3   | ETX (End of Text)             |
| 04  | 4   | EOT (End of Transmission)     |
| 05  | 5   | ENQ (Enquiry)                 |
| 06  | 6   | ACK (Acknowledgment)          |
| 07  | 7   | BEL (Bell)                    |
| 08  | 8   | BS (Backspace)                |
| 09  | 9   | HT (Horizontal Tab)           |
| 0a  | 10  | LF (Line Feed)                |
| 0b  | 11  | VT (Vertical Tab)             |
| 0c  | 12  | FF (Form Feed)                |
| 0d  | 13  | CR (Carriage Return)          |
| 0e  | 14  | SO (Shift Out)                |
| 0f  | 15  | SI (Shift In)                 |
| 10  | 16  | DLE (Data Link Escape)        |
| 11  | 17  | DC1 (XON) (Device Control 1)  |
| 12  | 18  | DC2 (Device Control 2)        |
| 13  | 19  | DC3 (XOFF) (Device Control 3) |
| 14  | 20  | DC4 (Device Control 4)        |
| 15  | 21  | NAK (Negative Acknowledgment) |
| 16  | 22  | SYN (Synchronous Idle)        |
| 17  | 23  | ETB (End of Trans. Block)     |
| 18  | 24  | CAN (Cancel)                  |
| 19  | 25  | EM (End of Medium)            |
| 1a  | 26  | SUB (Substitute)              |
| 1b  | 27  | ESC (Escape)                  |
| 1c  | 28  | FS (File Separator)           |
| 1d  | 29  | GS (Group Separator)          |
| 1e  | 30  | RS (Request to Send)          |
| 1f  | 31  | US (Unit Separator)           |

---

|    |    |                                 |
|----|----|---------------------------------|
| 20 | 32 | SP (Space)                      |
| 21 | 33 | ! (Exclamation Mark)            |
| 22 | 34 | " (Double Quote)                |
| 23 | 35 | # (Number Sign)                 |
| 24 | 36 | \$ (Dollar Sign)                |
| 25 | 37 | % (Percent)                     |
| 26 | 38 | & (Ampersand)                   |
| 27 | 39 | ` (Single Quote)                |
| 28 | 40 | ( (Right / Closing Parenthesis) |
| 29 | 41 | ) (Right / Closing Parenthesis) |
| 2a | 42 | * (Asterisk)                    |
| 2b | 43 | + ( )                           |
| 2c | 44 | , (Comma)                       |
| 2d | 45 | - (Minus / Dash)                |
| 2e | 46 | . (Dot)                         |
| 2f | 47 | / (Forward Slash)               |
| 30 | 48 | 0                               |
| 31 | 49 | 1                               |
| 32 | 50 | 2                               |
| 33 | 51 | 3                               |
| 34 | 52 | 4                               |
| 35 | 53 | 5                               |
| 36 | 54 | 6                               |
| 37 | 55 | 7                               |
| 38 | 56 | 8                               |
| 39 | 57 | 9                               |
| 3a | 58 | : (Colon)                       |
| 3b | 59 | ; (Semi-colon)                  |
| 3c | 60 | < (Less Than)                   |
| 3d | 61 | = (Equal Sign)                  |
| 3e | 62 | > (Greater Than)                |
| 3f | 63 | ? (Question Mark)               |
| 40 | 64 | @ (AT Symbol)                   |
| 41 | 65 | A                               |
| 42 | 66 | B                               |

|    |     |                             |
|----|-----|-----------------------------|
| 43 | 67  | C                           |
| 44 | 68  | D                           |
| 45 | 69  | E                           |
| 46 | 70  | F                           |
| 47 | 71  | G                           |
| 48 | 72  | H                           |
| 49 | 73  | I                           |
| 4a | 74  | J                           |
| 4b | 75  | K                           |
| 4c | 76  | L                           |
| 4d | 77  | M                           |
| 4e | 78  | N                           |
| 4f | 79  | O                           |
| 50 | 80  | P                           |
| 51 | 81  | Q                           |
| 52 | 82  | R                           |
| 53 | 83  | S                           |
| 54 | 84  | T                           |
| 55 | 85  | U                           |
| 56 | 86  | V                           |
| 57 | 87  | W                           |
| 58 | 88  | X                           |
| 59 | 89  | Y                           |
| 5a | 90  | Z                           |
| 5b | 91  | [ (Left / Opening Bracket)  |
| 5c | 92  | \ (Back Slash)              |
| 5d | 93  | ] (Right / Closing Bracket) |
| 5e | 94  | ^ (Caret / Circumflex)      |
| 5f | 95  | _ (Underscore)              |
| 60 | 96  | ' (Grave Accent)            |
| 61 | 97  | a                           |
| 62 | 98  | b                           |
| 63 | 99  | c                           |
| 64 | 100 | d                           |
| 65 | 101 | e                           |

|    |     |                         |
|----|-----|-------------------------|
| 66 | 102 | f                       |
| 67 | 103 | g                       |
| 68 | 104 | h                       |
| 69 | 105 | i                       |
| 6a | 106 | j                       |
| 6b | 107 | k                       |
| 6c | 108 | l                       |
| 6d | 109 | m                       |
| 6e | 110 | n                       |
| 6f | 111 | o                       |
| 70 | 112 | p                       |
| 71 | 113 | q                       |
| 72 | 114 | r                       |
| 73 | 115 | s                       |
| 74 | 116 | t                       |
| 75 | 117 | u                       |
| 76 | 118 | v                       |
| 77 | 119 | w                       |
| 78 | 120 | x                       |
| 79 | 121 | y                       |
| 7a | 122 | z                       |
| 7b | 123 | { (Left/ Opening Brace) |
| 7c | 124 | (Vertical Bar)          |
| 7d | 125 | } (Right/Closing Brace) |
| 7e | 126 | ~ (Tilde)               |
| 7f | 127 | DEL (Delete)            |

---

## Appendix 5: Digit Barcodes

After scanning numeric barcode(s), you need to scan the **Save** barcode to save the data.

**0~9**



0000000

**【0】**



0000010

**【1】**



0000020

**【2】**



0000030

**【3】**



0000040

**【4】**



0000050

**【5】**



0000060

**【6】**



0000070

**【7】**



0000080

**【8】**



0000090

**【9】**

---

A~F



0000100

**【A】**



0000110

**【B】**



0000120

**【C】**



0000130

**【D】**



0000140

**【E】**



0000150

**【F】**

---

## Appendix 6: Save/Cancel Barcodes

After reading numeric barcode(s), you need to scan the **Save** barcode to save the data. If you scan the wrong digit(s), you can either scan the **Cancel** barcode and then start the configuration all over again, or scan the **Delete the Last Digit** barcode and then the correct digit, or scan the **Delete All Digits** barcode and then the digits you want.

For instance, after reading the **Maximum Length** barcode and numeric barcodes “1”, “2” and “3”, you scan:

- ✧ **Delete the Last Digit:** The last digit “3” will be removed.
- ✧ **Delete All Digits:** All digits “123” will be removed.
- ✧ **Cancel:** The maximum length configuration will be cancelled. And the scanner is still in the setup mode.



**【 Save 】**



**【 Cancel 】**



**【 Delete the Last Digit 】**



**【 Delete All Digits 】**

## Appendix 7: ASCII Function Key Mapping Table

| ASCII Function                | ASCII Value (HEX) | No Function Key Mapping | Function Key Mapping    |
|-------------------------------|-------------------|-------------------------|-------------------------|
| NUL (Null char.)              | 00                | Null                    | Ctrl+2                  |
| SOH (Start of Header)         | 01                | Keypad Enter            | Ctrl+A                  |
| STX (Start of Text)           | 02                | Caps Lock               | Ctrl+B                  |
| ETX (End of Text)             | 03                | Null                    | Ctrl+C                  |
| EOT (End of Transmission)     | 04                | Null                    | Ctrl+D                  |
| ENQ (Enquiry)                 | 05                | Null                    | Ctrl+E                  |
| ACK (Acknowledgment)          | 06                | Null                    | Ctrl+F                  |
| BEL (Bell)                    | 07                | Enter                   | Ctrl+G                  |
| BS (Backspace)                | 08                | Left Arrow              | Ctrl+H                  |
| HT (Horizontal Tab)           | 09                | Horizontal Tab          | Ctrl+I                  |
| LF (Line Feed)                | 0A                | Down Arrow              | Ctrl+J                  |
| VT (Vertical Tab)             | 0B                | Vertical Tab            | Ctrl+K                  |
| FF (Form Feed)                | 0C                | Backspace               | Ctrl+L                  |
| CR (Carriage Return)          | 0D                | Enter                   | Ctrl+M                  |
| SO (Shift Out)                | 0E                | Insert                  | Ctrl+N                  |
| SI (Shift In)                 | 0F                | Esc                     | Ctrl+O                  |
| DLE (Data Link Escape)        | 10                | F11                     | Ctrl+P                  |
| DC1 (XON) (Device Control 1)  | 11                | Home                    | Ctrl+Q                  |
| DC2 (Device Control 2)        | 12                | Print Screen            | Ctrl+R                  |
| DC3 (XOFF) (Device Control 3) | 13                | Delete                  | Ctrl+S                  |
| DC4 (Device Control 4)        | 14                | tab+shift               | Ctrl+T                  |
| NAK (Negative Acknowledgment) | 15                | F12                     | Ctrl+U                  |
| SYN (Synchronous Idle)        | 16                | F1                      | Ctrl+V                  |
| ETB (End of Trans. Block)     | 17                | F2                      | Ctrl+W                  |
| CAN (Cancel)                  | 18                | F3                      | Ctrl+X                  |
| EM (End of Medium)            | 19                | F4                      | Ctrl+Y                  |
| SUB (Substitute)              | 1A                | F5                      | Ctrl+Z                  |
| ESC (Escape)                  | 1B                | F6                      | See the following table |
| FS (File Separator)           | 1C                | F7                      |                         |
| GS (Group Separator)          | 1D                | F8                      |                         |
| RS (Request to Send)          | 1E                | F9                      |                         |
| US (Unit Separator)           | 1F                | F10                     |                         |



---

## ASCII Function Key Mapping Table (Continued)

The function key mappings of the last five characters in the previous table differ from one keyboard layout to another.

| Country/<br>Keyboard Layout | Function Key Mapping |        |         |        |        |
|-----------------------------|----------------------|--------|---------|--------|--------|
|                             | 1B                   | 1C     | 1D      | 1E     | 1F     |
| United States               | Ctrl+[               | Ctrl+\ | Ctrl+]  | Ctrl+6 | Ctrl+- |
| Belgium                     | Ctrl+[               | Ctrl+< | Ctrl+]  | Ctrl+6 | Ctrl+- |
| Scandinavia                 | Ctrl+8               | Ctrl+< | Ctrl+9  | Ctrl+6 | Ctrl+- |
| France                      | Ctrl+^               | Ctrl+8 | Ctrl+\$ | Ctrl+6 | Ctrl+= |
| Germany                     |                      | Ctrl+Ã | Ctrl++  | Ctrl+6 | Ctrl+- |
| Italy                       |                      | Ctrl+\ | Ctrl++  | Ctrl+6 | Ctrl+- |
| Switzerland                 |                      | Ctrl+< | Ctrl+.  | Ctrl+6 | Ctrl+- |
| United Kingdom              | Ctrl+[               | Ctrl+∅ | Ctrl+]  | Ctrl+6 | Ctrl+- |
| Denmark                     | Ctrl+8               | Ctrl+\ | Ctrl+9  | Ctrl+6 | Ctrl+- |
| Norway                      | Ctrl+8               | Ctrl+\ | Ctrl+9  | Ctrl+6 | Ctrl+- |
| Spain                       | Ctrl+[               | Ctrl+\ | Ctrl+]  | Ctrl+6 | Ctrl+- |

---

## Appendix 8: Code Pages List

| Numeric Barcode Needed | Code Page               |
|------------------------|-------------------------|
| 0                      | Windows 1252 (Latin I)  |
| 1                      | Windows 1251 (Cyrillic) |



Headquarters

Fujian Newland Auto-ID Tech. Co., Ltd.

3F, Building A, No.1, Rujiang West Rd., Mawei, Fuzhou,  
Fujian, China 350015

TEL: +86 - (0) 591-83979222

FAX: +86 - (0) 591-83979208

E-mail: [marketing@nlscan.com](mailto:marketing@nlscan.com)

WEB: [www.nlscan.com](http://www.nlscan.com)

Newland Europe BV

Rolweg 25, 4104 AV Culemborg, The Netherlands

TEL: +31 (0) 345 87 00 33

FAX: +31 (0) 345 87 00 39

Email: [info@newland-id.com](mailto:info@newland-id.com)

WEB: [www.newland-id.com](http://www.newland-id.com)

Tech Support: [tech-support@newland-id.com](mailto:tech-support@newland-id.com)

Newland North America Inc.

Address: 46559 Fremont Blvd., Fremont, CA 94538, USA

TEL: 510 490 3888

Fax: 510 490 3887

Email: [info@newlandna.com](mailto:info@newlandna.com)

WEB: [www.newlandna.com](http://www.newlandna.com)

Newland Taiwan Inc.

7F-6, No. 268, Liancheng Rd., Zhonghe Dist. 235, New  
Taipei City, Taiwan

TEL: +886 2 7731 5388

FAX: +886 2 7731 5389

Email: [info@newland-id.com.tw](mailto:info@newland-id.com.tw)

WEB: [www.newland-id.com.tw](http://www.newland-id.com.tw)